

Innovator

Innovator Gas Manifold Systems



TABLE OF CONTENTS



INDUSTRIAL MANIFOLDS

• DS1000 Series	4-5
• BI Series	6-7
• LC, LA Series	8-9
• MD, MS Series	10-11
• SD, SDLA Series	12-13
• Industrial Manifold Replacement Pigtails	14



HEALTHCARE MANIFOLDS

• FHM2 Series	16-17
• HGM2 Series	18-19
• AGM2 Series	20-21
• MLC Series	22-23
• MCLA Series	24
• Dual Line Regulator Assemblies	25
• Healthcare Manifold Replacement Pigtails	26



SPECIALTY GAS MANIFOLDS

• HBAC2 Series	28-29
• LAB Series	30
• HBCS Series	31
• CS3000	32
• SA3350	33
• MC3000	34
• PS3000	35
• Specialty Gas Manifold Replacement Pigtails	36



ACCESSORIES

• Cylinder Brackets, Manifold Bracket & Mounting Hardware, Gas Heaters	38
• Flashback Arrestors, Fuel Gas Safety Kits, Fuel Gas Alarm Kits	39
• Pressure Switches, Remote Alarm Panels & Power Supplies	40
• Station Drops, Line Station Regulators, Flowmeters	41
• Manifold Regulators, In-Line Regulators	42
• Packless Diaphragm Valves, Bypass Valve Assembly, Header Valves	43
• 1/4 Turn Ball Valves, Master Valves, Line Station Valves	44
• Union Adaptors, Tailpieces & Nuts, Pipeline Check Valves, Check Valve Outlets, Relief Valves	45
• Header Components; Brass Pipe, Pipe Tees	46
• Header Components; Pipe Elbows, Pipe Crosses, Pipe Thread Caps & Plugs	47
• Purge Assemblies	48
• Notes	49
• Western Innovator Manifold Header Configurations	50

This catalog is for informational purposes. Specific information regarding the use of these products is contained in the Operating Instructions provided with each product. User/Installer is responsible for insuring installation has been done in accordance with federal, state, and local codes.



*Western Innovator's
Industrial Gas Manifolds are:*

- *Supported by a dedicated engineering staff and knowledgeable customer service representatives who are ready to help you customize a system built to your specific requirements.*
- *Cleaned and tested for the indicated gas service.*
- *1 year limited warranty.*

INDUSTRIAL MANIFOLDS

WESTERN INNOVATOR INDUSTRIAL GAS MANIFOLDS

Western Innovator Industrial Gas Manifolds offer the flexibility to meet your customer's individual manifold needs in today's competitive market. Our full line of Industrial Gas Manifolds provides the best value and highest quality in the industry.

DS1000

Western Innovator DS1000 Digital Manifolds provide fully automatic system control. An Integrated Circuit Board monitors cylinder bank pressure electronically, controlling changeover and eliminating the need to manually reset

levers or valves. Easy-to-read digital displays show the delivery and individual bank pressures. A series of lights for each bank indicates whether the bank is "in service", "ready for use", or "bank depleted".

specifications

- Fully Automatic Digital System—no levers to reset
- CSA Approved Power Source included
- LED Indicators provide system status for each bank. Lights will indicate "in service", "ready for use", or "bank depleted"
- Large digital display provides constant readout of bank pressure and delivery pressure
- Displays readout in psig, kPa or Bar
- Micro controller monitors all functions and controls changeover
- Maximum Inlet pressure: 3000 psig (2000 psig for DS1000HL)
- Delivery Pressure:
 - DS1000 40–100 psig
 - DS1000HL 40–100 psig
 - DS1000HP 100–190 psig
- Maximum Flow:
 - DS1000 2000 scfh
 - DS1000 35 scfh (CO₂ & N₂O)
 - DS1000 HL 500 scfh (CO₂ & N₂O with heater)
 - DS1000HP 2500 scfh
- Manifold Outlet: 1/2" NPT male
- Relief Valve Outlet: 1/2" NPT male
- 1/2" brass, silver brazed headers
- 24" flexible stainless steel braided pigtailed with check valves
- Connects to remote alarm systems (Up to 3 amps 30 VDC or 2 amps 250 VAC)



HOW TO ORDER

To Order: Specify—Model # (V)—Gas Service (W)—# of			
MODEL # (V)	GAS SERVICE (W)		# OF CYL'S (X)
DS1000 (40–100 psig)	(2) Air	CGA-346	
DS1000HL (40–100 psig) (For CO ₂ and N ₂ O -includes 500 scfh heater)	(3) Argon	CGA-580	
	(4) Carbon Dioxide	CGA-320	
DS1000HP (100–190 psig)	(5) Helium	CGA-580	
	(7) Nitrogen	CGA-580	
	(8) Nitrous Oxide	CGA-326	
	(9) Oxygen	CGA-540	

DS 10000 series

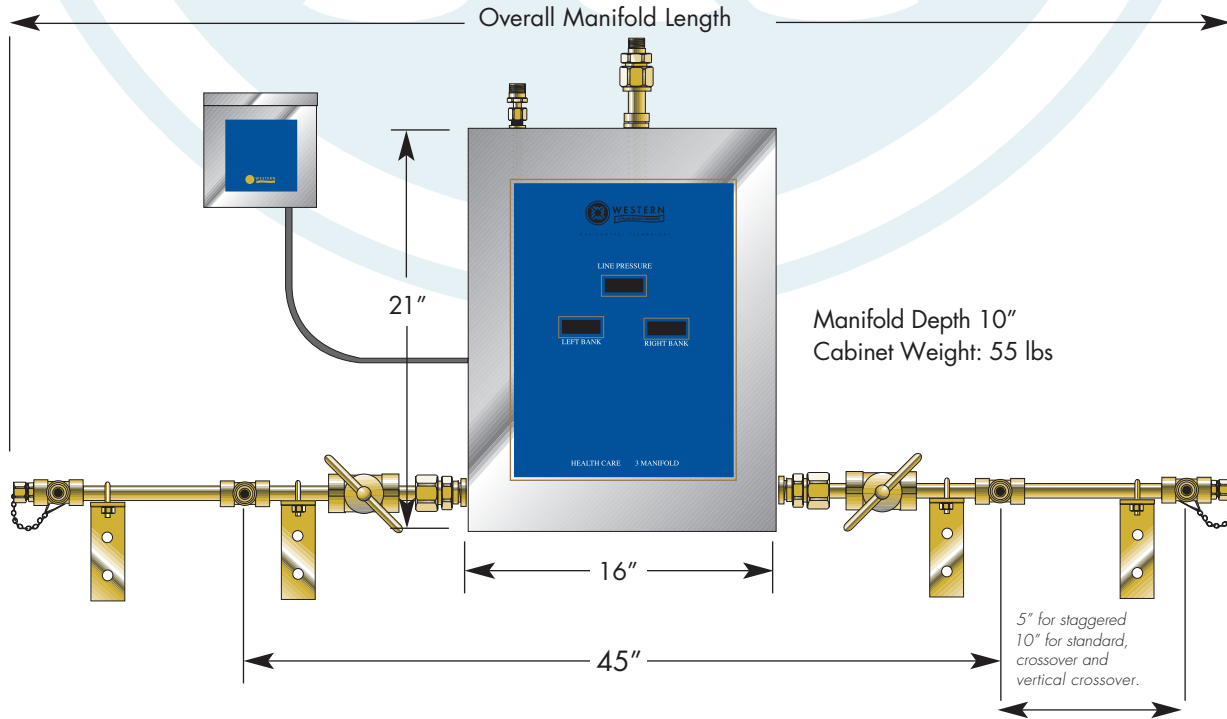

Example: DS1000-9-4=Oxygen (9=CGA-540) Manifold for 4 cylinders

*Not for hospital applications. Does not meet NFPA-99 requirement for hospital use.
See Western Innovator model FHM2, Fully Automatic Changeover Manifold.*

Cylinders (X)-Header Configuration (Y)-Mounting (Z)		
	HEADER CONFIGURATION (Y)	MOUNTING (Z)
	BLANK -Standard 10" on Center S -Staggered 5" on Center V -Vertical crossover 10" on Center C -Crossover (Floor Mount Only) Standard 10" on Center	BLANK = Wall mount F = Floor mounted (Floor Stand option required with Crossover option)

BI

Western Innovator BI Series Analog Manifolds are specifically designed to regulate and provide uninterrupted gas supply for industrial applications. Factory-set functional components are protected inside a tamper-resistant case. A green light indicates the service bank is functioning and

the reserve bank is ready for service. A red light alerts the user that the unit has changed over and one or both banks are depleted (except on fuel gas units). A simple rotation of the control lever resets the unit.

specifications

- Automatic Analog System
- CSA Approved Power Supply Included
- Maximum inlet pressure:
 - BI 3000 psig
 - BI (CO₂ & N₂O) 2000 psig
 - BI (Acetylene, LPG) 400 psig
 - BIHL (CO₂ & N₂O) 2000 psig
 - BIHP 3000 psig
 - BIHP (CO₂ & N₂O) 2000 psig
- Maximum flow rate:
 - BI 1200 scfh
 - BI (Acetylene) 300 scfh
 - BI (LPG) 400 scfh
 - BI (CO₂ & N₂O) 35 scfh
 - BIHL (CO₂ & N₂O) 500 scfh
 - BIHP 1200 scfh
- Internal adjustable line regulator:
 - BI & BIHL 30–125 psig
 - Acetylene 0–15 psig
 - LPG 0–30 psig
 - BIHP 50–200 psig
- Manifold outlet: 1/2" NPT male
- Relief valve outlet: 3/4" NPT male
- 24" flexible stainless steel braided pigtailed with check valves
- 1/2" Brass, silver brazed headers
- Individual header valves at each cylinder location (units with 4 cylinders or larger—all gases except Oxygen). Oxygen units shipped with check valve outlets in place of header valves to provide added safety from heat of recompression
- Acetylene systems include:
 - 300 scfh flashback arrestor and piping. Pigtailed with individual flashback arrestors and check valves
- Fuel gas units do not include visual alarm, power supply, or any electrical components. Fuel gas alarm kits are available as an option.
- Connects to remote alarms systems (Up to 3 amps 30 VDC or 2 amps 250 VAC)



HOW TO ORDER

Specify: Control Type (V)–Service (W)–Number of Cylinders (X)		
Example 1: BI-9-12V represents BI with oxygen gas service and a vertical cylinder		
Example 2: BIHP-7-6 represents BIHP with nitrogen gas service with a standard cylinder		
CONTROL TYPE (V)	GAS SERVICE (W)	# OF CYL'S (X)
BI (30 to 125 psig Acetylene (0–15 psig) LPG (0–30 psig) BIHL (30 to 125 psig) (500 scfh heater included in HL model for CO ₂ and N ₂ O) BIHP (50 to 200 psig) (Higher delivery pressure—to 235 psig available upon request)	(1) Acetylene (POL)	CGA-510
	(1A) Acetylene (Commercial)	CGA-300
	(2) Air	CGA-346
	(3) Argon	CGA-580
	(4) Carbon Dioxide	CGA-320
	(5) Helium	CGA-580
	(6) Hydrogen	CGA-350
	(6A) Argon/Methane Mixtures	CGA-350
	(7) Nitrogen	CGA-580
	(7A) Industrial Air/Nitrogen OP	CGA-590
(8) Nitrous Oxide	CGA-326	
(9) Oxygen	CGA-540	
(10) Liquefied Fuel Gases (LPG)	CGA-510	

BI series

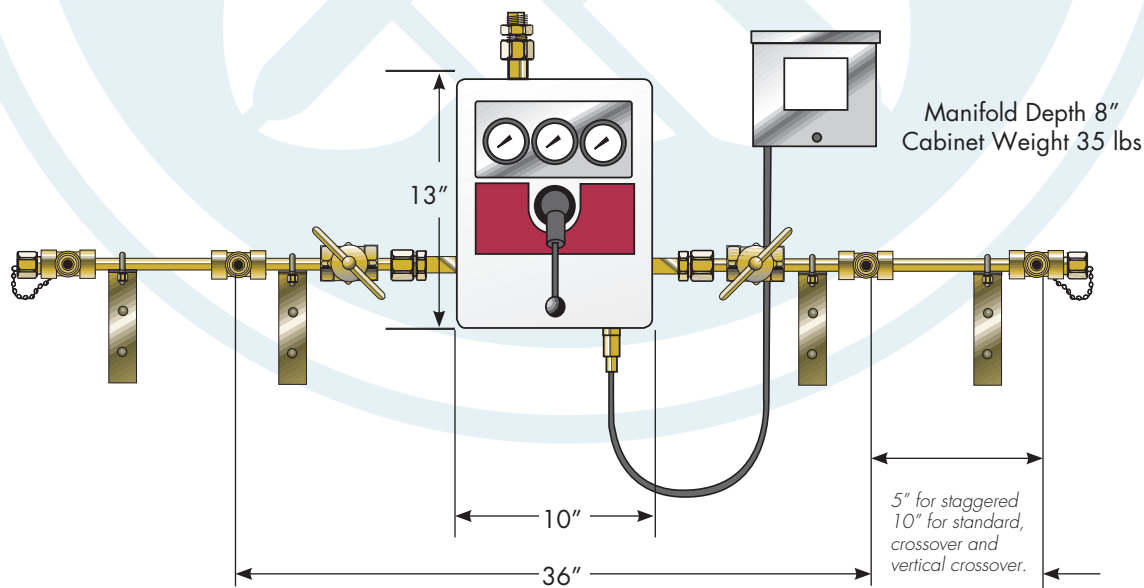

Example: BI-9-4 = Oxygen (9=CGA-540) Manifold for 4 Cylinders

Design Lengths

TOTAL NO. OF CYLINDERS	2	4	6	8	10	12	16
Standard (10" CENTERS) Overall Manifold Length	2'-0" (0.61m)	5'-5" (1.65m)	7'-1" (2.16m)	8'-9" (2.67m)	10'-5" (3.18m)	11'-9" (3.58m)	15'-3" (4.65m)
Staggered Design (5" CENTERS) Overall Manifold Length	2'-0" (0.61m)	4'-7" (1.40m)	5'-5" (1.65m)	6'-3" (1.91m)	7'-1" (2.16m)	7'-11" (2.4m)	9'-7" (2.92m)
Vertical Crossover (10" CENTERS) Overall Manifold Length	N/A	3'-9" (1.14m)	N/A	5'-5" (1.65m)	N/A	7'-1" (2.16m)	8'-9" (2.67m)
Crossover (10" CENTERS) Overall Manifold Length	N/A	3'-9" (1.14m)	N/A	5'-5" (1.65m)	N/A	7'-1" (2.16m)	8'-9" (2.67m)
Acetylene Manifold (13" CENTERS) Overall Manifold Length	2'-0" (0.61m)	5'-9" (1.75m)	8'-0" (2.44m)	10'-2" (3.10m)	12'-4" (3.76m)	14'-5" (4.40m)	16'-7" (5.06m)

Cylinders (X)-Header Configuration (Y)-Mounting (Z)

Standard crossover bank of 6 cylinders per side which is mounted on the wall.
Standard header configuration of 3 cylinders per side which is mounted on the wall.

HEADER CONFIGURATION (Y)	MOUNTING (Z)
BLANK -Standard 10" on Center 13" on Center for Acetylene & LPG S -Staggered 5" on Center 6.5" on Center for Acetylene & LPG V -Vertical crossover Standard 10" on Center 13" on Center for Acetylene & LPG C -Crossover (Floor Mount Only) Standard 10" on Center 13" on Center for Acetylene & LPG U-Shaped -Drawing Required L-Shaped -Drawing Required	BLANK = Wall mount F = Floor mounted

LC (Cryogenic Cylinder-Gas Withdrawal)

Western Innovator LC Manifolds are designed to regulate and monitor vaporized gas from cryogenic cylinders. Convenient and easy to use, the system automatically changes over when the primary cylinder bank is depleted. Simply rotate the control lever to reset the unit.

A self-contained alarm system alerts the user to the system's current status. A green light indicates the service bank is functioning and the reserve bank is ready for service. A red light signals that the system has changed over and one or both banks are depleted.

specifications

- Automatic Analog System
- Gas withdrawal from Liquid Dewars
- CSA Approved Power Source Included
- Maximum inlet pressure: 350 psig
- Maximum flow rate:
 - LC 750 scfh
 - LCHP 800 scfh
- Adjustable line regulator:
 - LC 40-85 psig
 - LCHP 40-180 psig
- Manifold outlet: 1/2" NPT male
- Relief valve outlet: 1/4" NPT male
- 7/2" Cryogenic pigtailed with check valves
- Minimum inlet pressure:
 - LC 125 psig
 - LCHP 250 psig
- LC Series for use with 235 psig relief valve Dewars
- LCHP Series for use with 350 psig relief valve Dewars
- Connects to remote alarms systems (Up to 3 amps 30 VDC or 2 amps 250 VAC)



Example: LC-7-2 = Nitrogen (7=CGA-580) Manifold for 2 Liquid Cylinders.

HOW TO ORDER

Specify: Control Type (V)-Service (W)-Number of Cylinders (X)-Mounting (Z)			
Example: LC-3-4 represents LC with Argon gas service for 2 cryogenic cylinders per side which is mounted on the wall.			
CONTROL TYPE (V)	GAS SERVICE (W)	# OF CYL'S (X)	MOUNTING (Z)
LC (40-85 psig)	(3) Argon (4) Carbon Dioxide	CGA-580 CGA-320	BLANK = Wall mount F = Floor mounted
LCHP (40-180 psig) (Nitrogen units only are adjustable - 40-210 psig)	(5) Helium (7) Nitrogen (8) Nitrous Oxide (9) Oxygen	CGA-580 CGA-580 CGA-326 CGA-540	

Note: Manifold system flow is limited by the max. flow capacity of the liquid cylinder. Consult cylinder manufacturer for flow data. System flow capacity may be increased with the addition of liquid cylinders.

Note: To maximize flow performance when more than one cylinder is used, pigtailed should be used to connect the vent lines to ensure equalized cylinder pressure.

LA (Cryogenic Cylinder-Gas Withdrawal X High Pressure)

Western Innovator LA manifolds are designed for applications using cryogenic cylinders as a primary gas source, but usage is insufficient to warrant liquid as a reserve. This LA series manifold will automatically switch over from service to reserve bank without any interruption of service. Line pressure will remain

constant within a variation of $\pm 2\%$ throughout the changeover cycle. An alarm can be added to signal changeover from service to reserve banks by adding items: WME-4-9 pressure switch, WMS-1-97 orificed adaptor, WMS-9-25C power supply box and BIA-3 remote audio visual alarm.

specifications

- Automatic L x HP System
- Gas withdrawal from Liquid Dewars
- Maximum working pressure for high pressure reserve system: 3000 psig
- Maximum flow capacity: 750 scfh-Model LA
750 scfh-Model LAMP
800 scfh-Model LAHP
- Adjustable cryogenic line regulator: 40-85 psig on LA Series
40-130 psig on LAMP Series
40-210 psig on LAHP Series
- Manifold outlet: 1/2" NPT male
- 24" flexible stainless steel braided pigtails with check valves, for high pressure bank
- Cryogenic side includes 72" cryogenic pigtails with check valves (nylon inner core with polyester braid). Maximum working pressure 1375 psig
- Inlet pressures from each liquid cylinder must be the same*
- Individual header valves at each cylinder location (units with 2 cylinders or larger-all gases except Oxygen). Oxygen units shipped with check valve outlets in place of header valves to provide added safety from heat of recompression
- 1/2" Brass, silver brazed headers

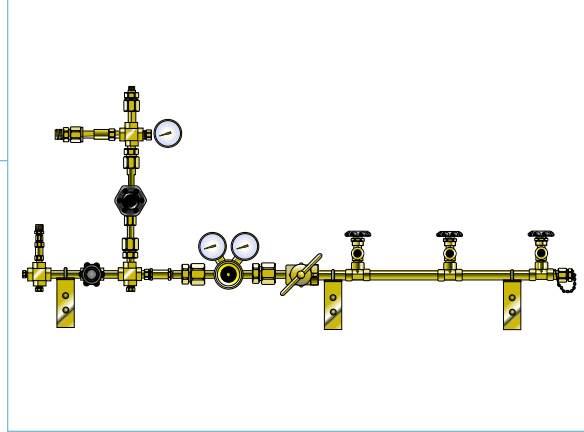

Example: LA-7-2-3 = Nitrogen (7=CGA-580)
Manifold for 2 Liquid Cylinders and 3 H.P. Cylinders.

Minimum inlet pressure for LA 125 psig (860 kPa)*

Minimum inlet pressure for LAMP 160 psig (1100 kPa)*

Minimum inlet pressure for LAHP 250 psig (1700 kPa)*

HOW TO ORDER

Specify: Control Type (U)-Service (V)-No. of Liq. (W)-No. of HP (X)-Header (Y)-Mounting (Z)					
Example: LA-7-2-3 represents LA with Nitrogen gas service for 2 liquid cylinders and 3 H.P. cylinders, mounted on the wall.					
CONTROL TYPE (U)	GAS SERVICE (V)	# OF LIQUID VESSELS (W)	# OF CYL'S (X)	HEADER CONFIGURATION (Y)	MOUNTING (Z)
LA (40-85 psig)	(3) Argon CGA-580			BLANK -Standard 10" on Center	BLANK = Wall mount
LAMP (40-130 psig)	(4) Carbon Dioxide CGA-320			S -Staggered 5" on Center	F = Floor mounted
LAHP (40-210 psig)	(5) Helium CGA-580			V -Vertical crossover Standard 10" on Center	
	(7) Nitrogen CGA-580			C -Crossover (Floor Mount Only) Standard 10" on Center	
	(8) Nitrous Oxide CGA-326				
	(9) Oxygen CGA-540				

MD, MS Manual Manifold Systems

Manual manifolds are designed to regulate compressed gases in high pressure cylinders (up to 3,000 psig) and are ideal for manifold applications not requiring automatic changeover from the service to the secondary bank. The MD Series duplex manifold is designed for manual

changeover of 2 banks of cylinders. The MS series simplex manifold system allows manifolding of an unlimited number of cylinders in a single bank. This system is often used as a high pressure reserve for bulk, portable bulk and gas generator systems.

specifications

- Manual Systems
- Maximum working pressure: 3000 psig
- Manifold Outlet: 1/2" NPT male
- 24" flexible stainless steel braided pigtails with check valves. Check valve is at header end of pigtail for all gases except Oxygen. Note: Helium and Hydrogen manifolds shipped with synthetic fiber braided pigtails
- Individual header valves at each cylinder location (units with 4 cylinders or larger—all gases except Oxygen)
- Headers constructed of 1/2" brass pipe and tees
- Acetylene manifolds shipped complete with dry flashback arrestor, relief valve and connecting piping. Hydraulic Flashback arrestors are available as an option for an additional charge
- Optional safety kits, flash arrestor and relief valve available for Liquefied Fuel gases
- Heater Kits available for Carbon Dioxide and Nitrous Oxide gases
- Model RM regulator included for most gas services. Note: RDM Series used for Oxygen
- An alarm can be added to non fuel gas MD systems to signal changeover from service to reserve banks by adding items WME-4-9 pressure switch, WMS-1-97 adaptor, WMS-9-25C power source and BIA-3 remote A/V alarm.

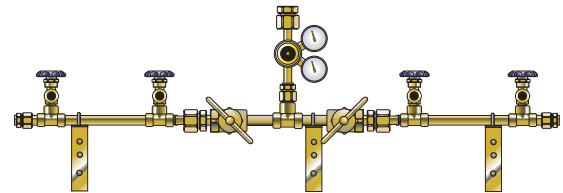

MD-4-4

Example: MD-4-4 = CO₂ (4=CGA-320)
Manifold for 4 Cylinders



MS-9-4

Example: MS-9-4 = Oxygen (9=CGA-540)
Manifold for 4 cylinders

HOW TO ORDER

Specify: Control Type (V)–Service (W)–Number of Cylinders (X)		
Example 1: MD-9-12V represents MD with oxygen gas service and a vented regulator		
Example 2: MSHP-7-6 represents MSHP with nitrogen gas service with a safety shut-off valve		
CONTROL TYPE (V)	GAS SERVICE (W)	# OF CYL'S (X)
MD / MS Most gases: 20–160 psig Acetylene: (0–15 psig) LPG: (0–45 psig)	(1) Acetylene (POL)	CGA-510
	(1A) Acetylene (Commercial)	CGA-300
	(2) Compressed Air	CGA-346
	(3) Argon	CGA-580
	(4) Carbon Dioxide	CGA-320
	(5) Helium	CGA-580
	(6) Hydrogen	CGA-350
	(6A) Argon/Methane Mixtures	CGA-350
	(7) Nitrogen	CGA-580
	(7A) Industrial Air/Nitrogen OP	CGA-590
MDHP / MSHP (only available for non-fuel gas services) Most gases: 140–300 psig Oxygen: 140–450 psig	(8) Nitrous Oxide	CGA-326
	(9) Oxygen	CGA-540
	(10) Liquefied Fuel Gases (LPG)	CGA-510

Note: Different regulators may be substituted to achieve higher delivery pressures on all control types.

MD, MS series

Design Lengths

TOTAL NO. OF CYLINDERS	2	3	4	5	6	7	8
MS- Standard (10" Centers) Overall Manifold Length	2'-9" (.84m)	3'-7" (1.09m)	4'-5" (1.35m)	5'-3" (1.60m)	6'-1" (1.85m)	7'-0" (2.13m)	7'-10" (2.39m)
MS- Staggered Design (5" Centers) Overall Manifold Length	2'-4" (.74m)	2'-9" (.84m)	3'-2" (.97m)	3'-7" (1.09m)	4'-0" (1.22m)	4'-5" (1.35m)	4'-10" (1.47m)
MS- Vertical Crossover and Crossover (10" Centers) Overall Manifold Length	1'-11" (.58m)	N/A	2'-9" (.84m)	N/A	3'-7" (1.09m)	N/A	4'-5" (1.35m)
MS- Standard (13" Centers) Overall Manifold Length	3'-0" (.91m)	4'-1" (1.22m)	5'-2" (1.57m)	6'-3" (1.91m)	7'-4" (2.24m)	8'-5" (2.57m)	9'-6" (2.90m)
MS- Staggered Design (6.5" Centers) Overall Manifold Length	2'-5.5" (.75m)	3'-0" (.91m)	3'-6.5" (1.08m)	4'-1" (1.25m)	4'-7.5" (1.41m)	5'-2" (1.57m)	5'-8.5" (1.74m)
MS- Vertical Crossover and Crossover (13" Centers) Overall Manifold Length	1'-11" (.58m)	N/A	3'-0" (.91m)	N/A	4'-1" (1.25m)	N/A	5'-2" (1.57m)
TOTAL NO. OF CYLINDER	2	4	6	8	10	12	14
MD- Standard (10" Centers) Overall Manifold Length	2'-4" (.71m)	4'-4" (1.32m)	6'-0" (1.83m)	7'-8" (2.34m)	9'-4" (2.85m)	11'-0" (3.35m)	12'-8" (3.86m)
MD- Staggered Design (5" Centers) Overall Manifold Length	2'-4" (.71m)	3'-6" (1.07m)	4'-4" (1.32m)	5'-2" (1.57m)	6'-0" (1.83m)	6'-10" (2.08m)	7'-8" (2.34m)
MD- Vertical Crossover and Crossover (10" Centers) Overall Manifold Length	N/A	2'-8" (.81m)	N/A	4'-4" (1.32m)	N/A	6'-0" (1.83m)	N/A
MD- Standard (13" Centers) Overall Manifold Length	2'-4" (.71m)	4'-9" (1.471m)	7'-0" (2.13m)	9'-2" (2.79m)	11'-4" (3.45m)	13'-6" (4.11m)	15'-8" (4.77m)
MD- Staggered Design (6.5" Centers) Overall Manifold Length	2'-4" (.71m)	3'-9" (1.14m)	4'-10" (1.47m)	5'-11" (1.80m)	7'-0" (2.13m)	8'-1" (2.46m)	9'-2" (2.79m)
MD- Vertical Crossover and Crossover (13" Centers) Overall Manifold Length	N/A	2'-8" (.81m)	N/A	4'-10" (1.47m)	N/A	7'-0" (2.13m)	N/A



Cylinders (X)-Header Configuration (Y)-Mounting (Z)

*Vertical crossover bank of 6 cylinders per side which is mounted on the wall.
Standard header configuration of 6 cylinders which is mounted on the wall.*

	HEADER CONFIGURATION (Y)	MOUNTING (Z)
	BLANK -Standard 10" on Center 13" on Center for Acetylene & LPG S -Staggered 5" on Center 6.5" on Center for Acetylene & LPG V -Vertical Crossover 10" on Center or 13" on Center for Acetylene & LPG C -Crossover (Floor Mount Only) 10" on Center or 13" on Center for Acetylene & LPG	BLANK = Wall mount F = Floor mounted

SD Manual System

Manual manifolds are designed to regulate compressed gases in high pressure cylinders (up to 3,000 psig) and are ideal for manifold applications not requiring automatic changeover from the service to the secondary bank. The SD

series simple duplex manifold is specifically designed as an economical system for a total capacity of two cylinders-one per side. Cylinders may be used one at a time maintaining a reserve or both at the same time for higher flow capacity.

SD, SDLA series

specifications

- Manual 2 cylinder System
- Maximum working pressure: 3000 psig
- Adjustable Line Regulator
 - SD 20-160 psig (most gases)
 - SDHP 140-300 psig (most gases)
- Model RM regulator included for most gas services
Note: RDM Series used for Oxygen
- Model RS-300-MAN regulator included for SDHP series manifolds
- Manifold Outlet: 1/2" NPT male
- 24" flexible stainless steel braided pigtails
- High quality header shut-off valves
- An alarm can be added to non fuel gas SD systems by adding items WME-4-9 pressure switch, WMS-1-97 adaptor, WMS-9-25C power source and BIA-3 remote A/V alarm.

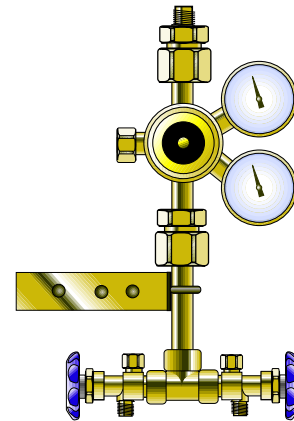

SD-7-2

HOW TO ORDER

Specify: Model # (X)-Gas Service (Y)-Number of Cylinders (Z)			
MODEL # (X)	GAS SERVICE (Y)		# OF CYL'S (Z)
SD Most Gases: 20 - 160 psig Acetylene: 0 - 15 psig LPG: 0 - 45 psig	(1) Acetylene (POL)	CGA-510	Always 2
	(1A) Acetylene (Commercial)	CGA-300	
	(2) Compressed Air	CGA-346	
	(3) Argon	CGA-580	
	(4) Carbon Dioxide	CGA-320	
	(5) Helium	CGA-580	
	(6) Hydrogen	CGA-350	
	(6A) Argon/Methane Mixtures	CGA-350	
	(7) Nitrogen	CGA-580	
	(7A) Industrial Air/Nitrogen OP	CGA-590	
SDHP: Only available for non-fuel gas service Most Gases: 140 - 300 psig Oxygen: 140 - 450 psig	(8) Nitrous Oxide	CGA-326	
	(9) Oxygen	CGA-540	
	(10) Liquefied Fuel Gases (LPG)	CGA-510	

Note: Helium and Hydrogen manifolds shipped with synthetic fiber braided pigtails.

SDLA Manual (Cryogenic Cylinder–Gas Withdrawal) System

Western Innovator SDLA Manual Changeover Manifolds are designed for applications requiring gas withdrawal from cryogenic cylinders. The SDLA manifolds are designed for use with up to

4 cylinders, 2 per bank, and can flow from both banks or one bank can be kept in reserve. An alarm can be added to signal when your primary bank is nearly depleted.

specifications

- Manual System
- Minimum inlet pressure:
 - SDLA 125 psig
 - SDLAHP 250 psig
- Maximum inlet pressure:
 - SDLA 350 psig
 - SDLAHP 350 psig
- Adjustable Line Regulator:
 - SDLA 40–100 psig
 - SDLAHP 80–210 psig
- Maximum Flow:
 - SDLA 750 scfh
 - SDLAHP 800 scfh
- SDLA series for use with 235 psig relief valve Dewars
- SDLAHP series for use with 350 psig relief valve Dewars
- Manifold Outlet: 1/2" NPT male
- Line relief valve outlet: 1/2" NPT female
- 7/2" Cryogenic pigtailed with check valves
- Includes high quality cryogenic master valves for low temperature operation
- Constructed of brass pipes and tees, labeled for indicated gas usage
- Wall mounting brackets included
- Options: Alarm Kit Part # SDLA-AK
Floor stand

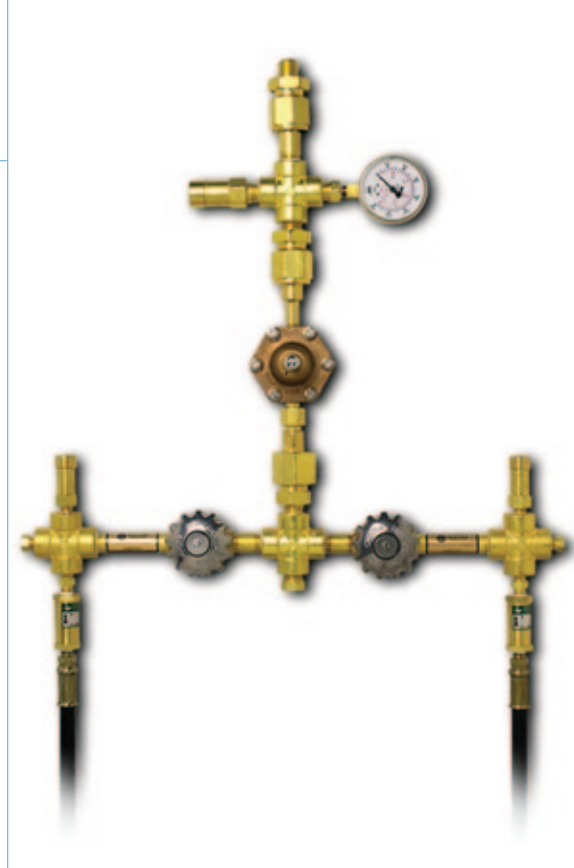

HOW TO ORDER

Specify: Model (W)–Gas Service (X)–Number of Cylinders (Y)–Mounting (Z)				
MODEL # (W)	GAS SERVICE (X)		# OF CYL'S (Y)	MOUNTING (Z)
SDLA (40–100 psig)	(3)	Argon	CGA–580	4 Maximum BLANK = Wall mount F = Floor mounted
SDLAHP (80–210 psig)	(4)	Carbon Dioxide	CGA–320	
	(5)	Helium	CGA–580	
	(7)	Nitrogen	CGA–580	
	(8)	Nitrous Oxide	CGA–326	
	(9)	Oxygen	CGA–540	

Note: To maximize flow performance when more than one cylinder is used, pigtailed should be used to connect the vent lines to ensure equalized cylinder pressure.

INDUSTRIAL MANIFOLD REPLACEMENT PIGTAILS

DS1000, BI, SD, MD, MS, CLA, LA (high pressure side):

GAS	24"	36"
Acetylene (CGA 510)	PF-15CVFA-24R	PF-15CVFA-36R
Acetylene (CGA 300)	PF-16CVFA-24R	PF-16CVFA-36R
Compressed Air (CGA 346)	PF-346CV-24R	PF-346CV-36R
Argon (CGA 580)	PF-92CV-24R	PF-92CV-36R
Carbon Dioxide (CGA 320)	PF-320CV-24R	PF-320CV-36R
Helium (CGA 580)	PFS-92CV-24R	PFS-92CV-36R
Hydrogen (CGA 350)	PFS-83CV-24R	PFS-83CV-36R
Argon/Methane (CGA 350)	PF-83CV-24R	PF-83CV-36R
Nitrogen (CGA 580)	PF-92CV-24R	PF-92CV-36R
Industrial Air (CGA 590)	PF-93CV-24R	PF-93CV-36R
Nitrous Oxide (CGA 326)	PF-326CV-24R	PF-326CV-36R
Oxygen (CGA 540)	PF-63CV-24R	PF-63CV-36R
LPG (CGA 510)	PF-15CV-24R	PF-15CV-36R

LC, SDLA, LA (liquid cylinder side), (available in 72" length only)

GAS	72"
Argon (CGA 580)	WMH-2-8
Carbon Dioxide (CGA 320)	WMH-2-5
Nitrogen (CGA 580)	WMH-2-8
Nitrous Oxide (CGA 326)	WMH-2-6
Oxygen (CGA 540)	WMH-2-7



Western Innovator Healthcare Manifolds are:

- *Specifically designed to meet a wide variety of healthcare applications that require uninterrupted gas service. Systems automatically switch from the primary gas supply to the secondary gas supply.*
- *Designed and manufactured to meet NFPA-99 2012 safety and performance requirements.*
- *Cleaned and tested for the indicated gas service.*
- *1 year limited warranty.*

HEALTHCARE MANIFOLDS

WESTERN INNOVATOR HEALTHCARE MANIFOLD SYSTEMS

Western Innovator Healthcare Manifolds offer an extensive range of standard features, proven performance, outstanding value, and customization to meet special requirements.

FHM2

Western Innovator FHM2 Healthcare Gas Manifolds provide fully automatic system control. An integrated circuit board monitors cylinder bank pressure electronically, controlling change-over and eliminating the need to manually reset levers or valves.

FHM2 Healthcare Manifolds meet NFPA-99 2012 safety and performance requirements. Easy-to-read digital displays show the line and individual bank pressures. A series of lights for each bank indicates whether the bank is "in service", "ready for use", or "bank depleted".

specifications

- NFPA Compliant, Fully Automatic Digital System
- CSA Approved Power Supply included
- Maximum inlet pressure: 3000 psig (2000 for CO₂ & N₂O systems)
- Maximum Flow Rate:

FHM2	2000 scfh
FHM2 (CO ₂ & N ₂ O)	35 scfh
FHM2HL (CO ₂ & N ₂ O)	500 scfh
FHM2HP	3000 scfh
- Internal adjustable dual line regulators

FHM2 & FHM2HL	30-70 psig
FHM2HP	100-190 psig
- Manifold outlet: 1/2" NPT male
- Relief valve outlet: 1/2" NPT male
- 1/2" Brass, silver brazed headers
- Oxygen Pigtails: NFPA 99 compliant, rigid copper, with check valves, Other Gas Pigtails: NFPA 99 compliant, 24" flexible stainless steel with check valves
- Digital readout can display psig, kPa or Bar
- Connects to remote alarms systems (Up to 3 amps 30 VDC or 2 amps 250 VAC)



FHM2 series

HOW TO ORDER

Specify: Control Type (V)-Service (W)-Number of Cyl's (X)		
Example 1: FHM2HP-7-6 represents FHM2HP with nitrogen gas service with a 6 cylinder manifold		
CONTROL TYPE (V)	GAS SERVICE (W)	# OF CYL'S (X)
FHM2 (30 to 70 psig)	(2) Air CGA-346	
	(4) Carbon Dioxide CGA-320	
FHM2HL (30 to 70 psig) (For CO ₂ and N ₂ O- includes 500 scfh heater)	(5) Helium CGA-580	
	(7) Nitrogen CGA-580	
	(8) Nitrous Oxide CGA-326	
FHM2HP (100 to 190 psig)	(9) Oxygen CGA-540	

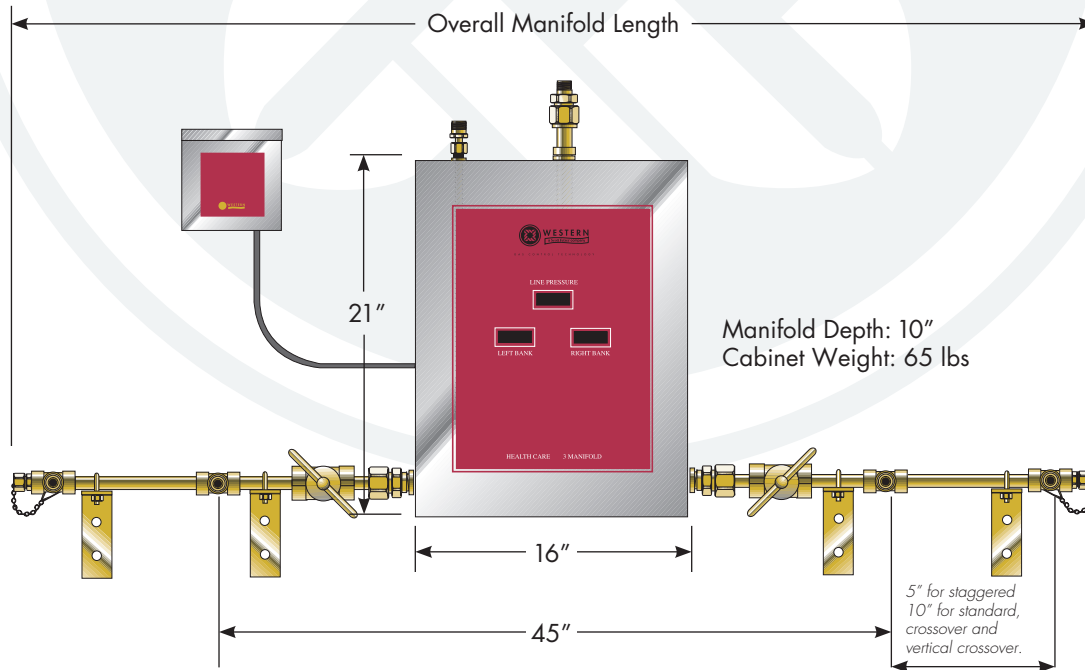

Example: FHM2-9-4-Oxygen (9=CGA-540) Manifold for 4 Cylinders

Design Lengths

TOTAL NO. OF CYLINDERS	4	6	8	10	12	16	20
Standard (10" Centers) Overall Manifold Length	5'-11" (1.80m)	7'-7" (2.31m)	9'-3" (2.82m)	10'-11" (3.33m)	12'-7" (3.84m)	15'-11" (4.85m)	19'-3" (5.87m)
Staggered Design (5" Centers) Overall Manifold Length	5'-1" (1.55m)	5'-11" (1.80m)	6'-9" (2.06m)	7'-7" (2.31m)	8'-5" (2.57m)	10'-1" (3.07m)	11'-9" (3.58m)
Vertical Crossover (10" Centers) Overall Manifold Length	4'-3" (1.30m)	N/A	5'-11" (1.80m)	N/A	7'-7" (2.31m)	9'-3" (2.82m)	10'-11" (3.33m)
Crossover (10" Centers) Overall Manifold Length	4'-3" (1.30m)	N/A	5'-11" (1.80m)	N/A	7'-7" (2.31m)	9'-3" (2.82m)	10'-11" (3.33m)



Cylinders (X)-Header Configuration (Y)-Mounting (Z)		
Standard header configuration of 3 cylinders per side which is mounted on the wall.		
	HEADER CONFIGURATION (Y)	MOUNTING (Z)
	<p>BLANK - Standard 10" on Center</p> <p>V - Vertical crossover 10" on Center</p> <p>S - Staggered 5" on Center</p> <p>C - Crossover 10" on Center</p> <p>U-Shaped - Drawing Required</p> <p>L-Shaped - Drawing Required</p>	<p>BLANK = Wall mount</p> <p>F = Floor mounted</p>

HGM2

Western Innovator HGM2 Manifolds are designed and manufactured according to NFPA-99 2012 safety and performance requirements. Easy-to-read digital displays indicate the line and individual bank pressures.

A green light means the service bank is functioning and the reserve bank is ready for service. A red light alerts the user that one or both banks are depleted. A simple rotation of the control lever resets the unit.

specifications

- NFPA Compliant, Automatic Digital System
- CSA Approved Power Supply included
- Maximum inlet pressure: 3000 psig (2000 for CO₂ & N₂O systems)
- Maximum Flow Rate:

HGM2	1200 scfh
HGM2	35 scfh
(CO ₂ & N ₂ O)	
HGM2HL	500 scfh
(CO ₂ & N ₂ O)	
HGM2HP	1200 scfh
- Internal adjustable dual line regulators

HGM2 & HGM2HL	30–55 psig
HGM2HP	50–200 psig
- Manifold outlet: 1/2" NPT male
- Relief valve outlet: 1/2" NPT male
- Oxygen Pigtails: NFPA 99 compliant, rigid copper, with check valves,
Other Gas Pigtails: NFPA 99 compliant, 24" flexible stainless steel with check valves
- 1/2" Brass, silver brazed headers
- Digital readout can display psig, kPa or Bar
- Connects to remote alarms systems (Up to 3 amps 30 VDC or 2 amps 250 VAC)



HGM2 series

HOW TO ORDER

Specify: Control Type (V)–Service (W)–Number of Cyls (X)		
Example 1: HGM2HP-7-6 represents HGM2HP with nitrogen gas service with a 6 cylinder manifold		
CONTROL TYPE (V)	GAS SERVICE (W)	# OF CYL'S (X)
HGM2 (30 to 55 psig)	(2) Air CGA-346	
	(4) Carbon Dioxide CGA-320	
HGM2HL (30 to 55 psig) (For CO ₂ and N ₂ O– includes 500 scfh heater)	(5) Helium CGA-580	
	(7) Nitrogen CGA-580	
	(8) Nitrous Oxide CGA-326	
	(9) Oxygen CGA-540	
HGM2HP (50 to 200 psig)		

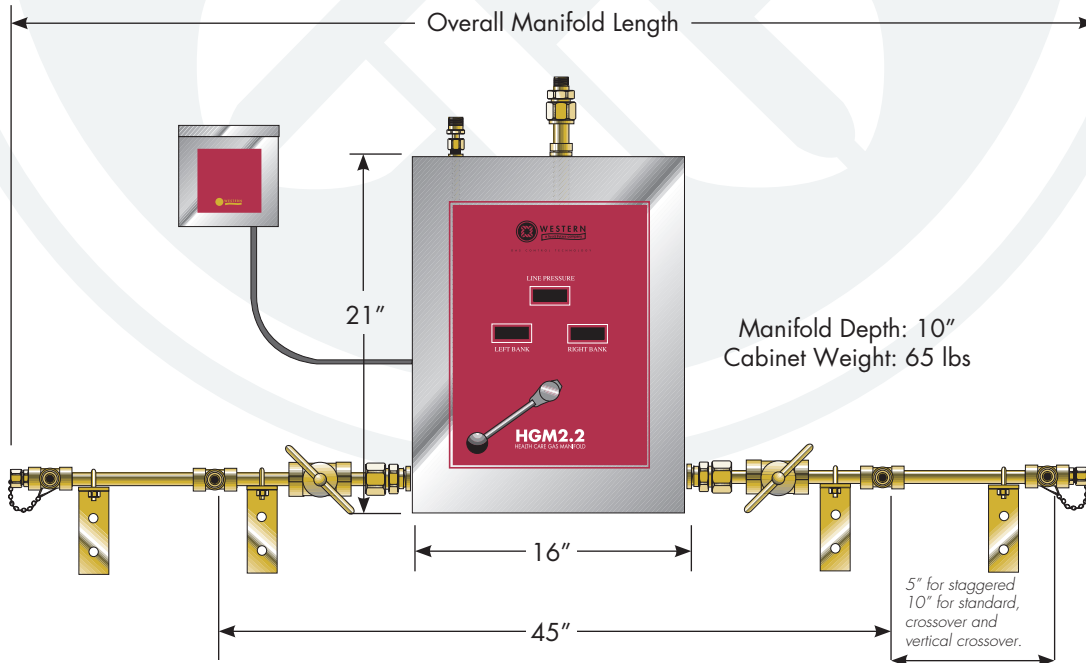

Example: HGM2-9-4 = Oxygen (9=CGA-540) Manifold for 4 Cylinders

Design Lengths

TOTAL NO. OF CYLINDERS	4	6	8	10	12	16	20
Standard (10" Centers) Overall Manifold Length	5'-11" (1.80m)	7'-7" (2.31m)	9'-3" (2.82m)	10'-11" (3.33m)	12'-7" (3.84m)	15'-11" (4.85m)	19'-3" (5.87m)
Staggered Design (5" Centers) Overall Manifold Length	5'-1" (1.55m)	5'-11" (1.80m)	6'-9" (2.06m)	7'-7" (2.31m)	8'-5" (2.57m)	10'-1" (3.07m)	11'-9" (3.58m)
Vertical Crossover (10" Centers) Overall Manifold Length	4'-3" (1.30m)	N/A	5'-11" (1.80m)	N/A	7'-7" (2.31m)	9'-3" (2.82m)	10'-11" (3.33m)
Crossover (10" Centers) Overall Manifold Length	4'-3" (1.30m)	N/A	5'-11" (1.80m)	N/A	7'-7" (2.31m)	9'-3" (2.82m)	10'-11" (3.33m)

Cylinders (X)-Header Configuration (Y)-Mounting (Z)

Standard header configuration of 3 cylinders per side which is mounted on the wall.

HEADER CONFIGURATION (Y)	MOUNTING (Z)
BLANK -Standard 10" on Center 	BLANK = Wall mount F = Floor mounted
V -Vertical crossover 10" on Center 	
S -Staggered 5" on Center 	
C -Crossover 10" on Center 	
U-Shaped - Drawing Required L-Shaped - Drawing Required	

AGM2

Western Innovator AGM2 Manifolds are designed and manufactured according to NFPA-99 2012 safety and performance requirements. Easy-to-read analog gauges indicate the line and individual bank pressures.

A green light means the service bank is functioning and the reserve bank is ready for service. A red light alerts the user that one or both banks are depleted. A simple rotation of the control lever resets the unit.

specifications

- NFPA Compliant, Automatic Analog System
- CSA Approved Power Supply included
- Maximum inlet pressure: 3000 psig (2000 for CO₂ & N₂O systems)
- Maximum Flow Rate:

AGM2	1200 scfh
AGM2 (CO ₂ & N ₂ O)	35 scfh
AGM2HL (CO ₂ & N ₂ O)	500 scfh
AGM2HP	1200 scfh
- Internal adjustable dual line regulators

AGM2 & AGM2HL	30–55 psig
AGM2HP	100–200 psig
- Manifold outlet: 1/2" NPT male
- Relief valve outlet: 1/2" NPT male
- Oxygen Pigtails: NFPA 99 compliant, rigid copper, with check valves
Other Gas Pigtails: NFPA 99 compliant, 24" flexible stainless steel with check valves
- 1/2" Brass, silver brazed headers
- Digital readout can display psig, kPa or Bar
- Connects to remote alarms systems (Up to 3 amps 30 VDC or 2 amps 250 VAC)



HOW TO ORDER

Specify: Control Type (V)–Service (W)–Number of Cyl's (X)			
Example 1: AGM2-7-6 represents AGM2 with nitrogen gas service with a standard control type			
CONTROL TYPE (V)	GAS SERVICE (W)		# OF CYL'S (X)
AGM2 (30 to 55 psig)	(2) Air	CGA-346	
	(4) Carbon Dioxide	CGA-320	
AGM2HL (30 to 55 psig) (For CO ₂ and N ₂ O– includes 500 scfh heater)	(5) Helium	CGA-580	
	(7) Nitrogen	CGA-580	
	(8) Nitrous Oxide	CGA-326	
	(9) Oxygen	CGA-540	
AGM2HP (100 to 200 psig)			

AGM2 series

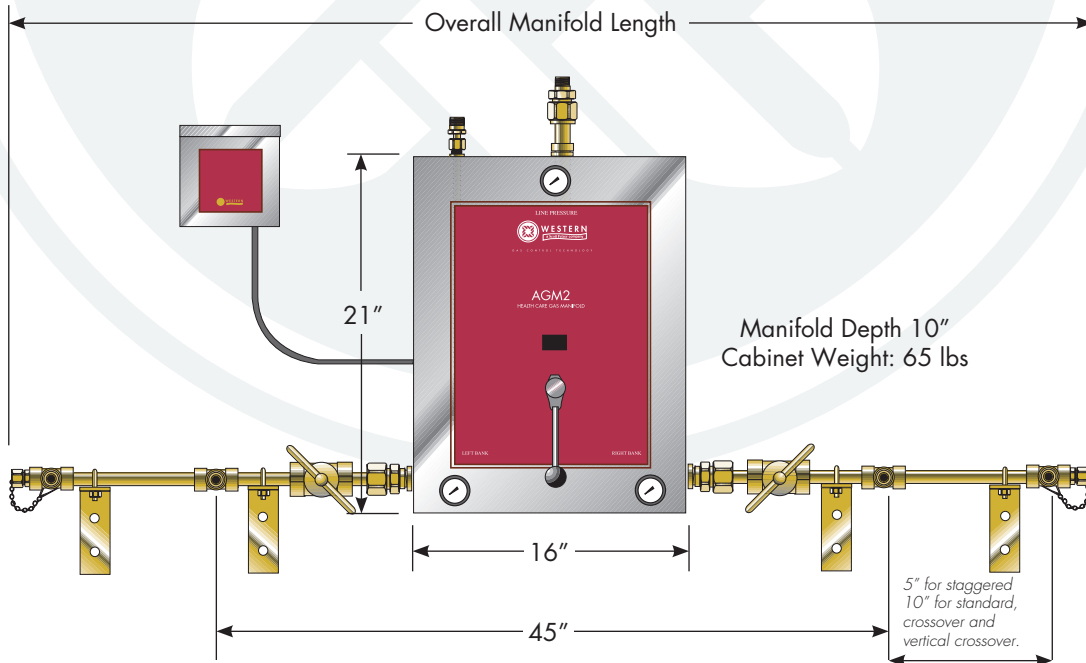

AGM2-9-4 = Oxygen (9=CGA-540) Manifold for 4 Cylinders

Design Lengths

TOTAL NO. OF CYLINDERS	4	6	8	10	12	16	20
Standard (10" Centers) Overall Manifold Length	5'-11" (1.80m)	7'-7" (2.31m)	9'-3" (2.82m)	10'-11" (3.33m)	12'-7" (3.84m)	15'-11" (4.85m)	19'-3" (5.87m)
Staggered Design (5" Centers) Overall Manifold Length	5'-1" (1.55m)	5'-11" (1.80m)	6'-9" (2.06m)	7'-7" (2.31m)	8'-5" (2.57m)	10'-1" (3.07m)	11'-9" (3.58m)
Vertical Crossover (10" Centers) Overall Manifold Length	4'-3" (1.30m)	N/A	5'-11" (1.80m)	N/A	7'-7" (2.31m)	9'-3" (2.82m)	10'-11" (3.33m)
Crossover (10" Centers) Overall Manifold Length	4'-3" (1.30m)	N/A	5'-11" (1.80m)	N/A	7'-7" (2.31m)	9'-3" (2.82m)	10'-11" (3.33m)

Cylinders (X)-Header Configuration (Y)-Mounting (Z)

Standard header configuration of 3 cylinders per side which is mounted on the wall.

HEADER CONFIGURATION (Y)	MOUNTING (Z)
<p>BLANK - Standard 10" on Center</p> <p>V - Vertical crossover 10" on Center</p> <p>S - Staggered 5" on Center</p> <p>C - Crossover 10" on Center</p> <p>U-Shaped - Drawing Required</p> <p>L-Shaped - Drawing Required</p>	<p>BLANK = Wall mount</p> <p>F = Floor mounted</p>



MLC - Liquid X Liquid with High Pressure Reserve

Western Innovator MLC and MLC Hybrid Manifolds are designed to regulate and monitor vaporized gas from cryogenic cylinders. The system automatically changes over when the primary cylinder bank is depleted. A simple rotation of the control lever resets the unit.

When used with Western's MCLA series high pressure reserve healthcare manifolds, dual line regulator assembly, pressure switches and check valves, the systems meet NFPA-99 2012 requirements.

specifications

- NFPA Compliant, Analog Automatic System
- CSA Approved Power Source included
- Adjustable line regulator
 - MLC 40–85 psig
 - MLCHP 40–180 psig
- Maximum flow: MLC 750 scfh
MLCHP 800 scfh
- Maximum inlet pressure: 350 psig (MLC)
- Manifold outlet: 1/2" NPT male
- Relief valve outlet: 1/4" NPT male
- 72" Cryogenic pigtails with check valves
- Minimum inlet pressure: MLC 125 psig
MLCHP 250 psig
- MLC Series for use with 235 psig relief valve Dewars
- MLCHP Series for use with 350 psig relief valve Dewars
- Connects to remote alarms systems
(Up to 3 amps 30 VDC or 2 amps 250 VAC)



HOW TO ORDER

Specify: Control Type (V)–Service (W)–Number of Liquid Cylinders (X) Number of Reserve H.P. Cylinders (Y)–Number of Secondary H.P. Cylinders (Z)				
Example: MLC-9-2-6 represents MLC with Oxygen gas service for 1 liquid cylinder per side, 6 HP Reserve Cylinders.				
CONTROL TYPE (V)	GAS SERVICE (W)	# OF LIQUID CYL'S (X)	# OF RESERVE HIGH PRESSURE CYLINDERS (Y)	# OF SECONDARY HIGH PRESSURE CYLINDERS (Z)*
MLC (40–85 psig)	(3) Argon CGA–580			
	(4) Carbon Dioxide CGA–320			
MLCHP (40–180 psig)	(7) Nitrogen CGA–580			
(Nitrogen units only are adjustable - 40–210 psig)	(8) Nitrous Oxide CGA–326			
	(9) Oxygen CGA–540			

*Hybrid only, Hybrid systems are designed for High Pressure cylinders as the secondary supply.

Note: Manifold system flow is limited by the max. flow capacity of the liquid cylinder. Consult cylinder manufacturer for flow data. System flow capacity may be increased with the addition of liquid cylinders.

MLC series

MLC Hybrid-Liquid X High Pressure with High Pressure Reserve

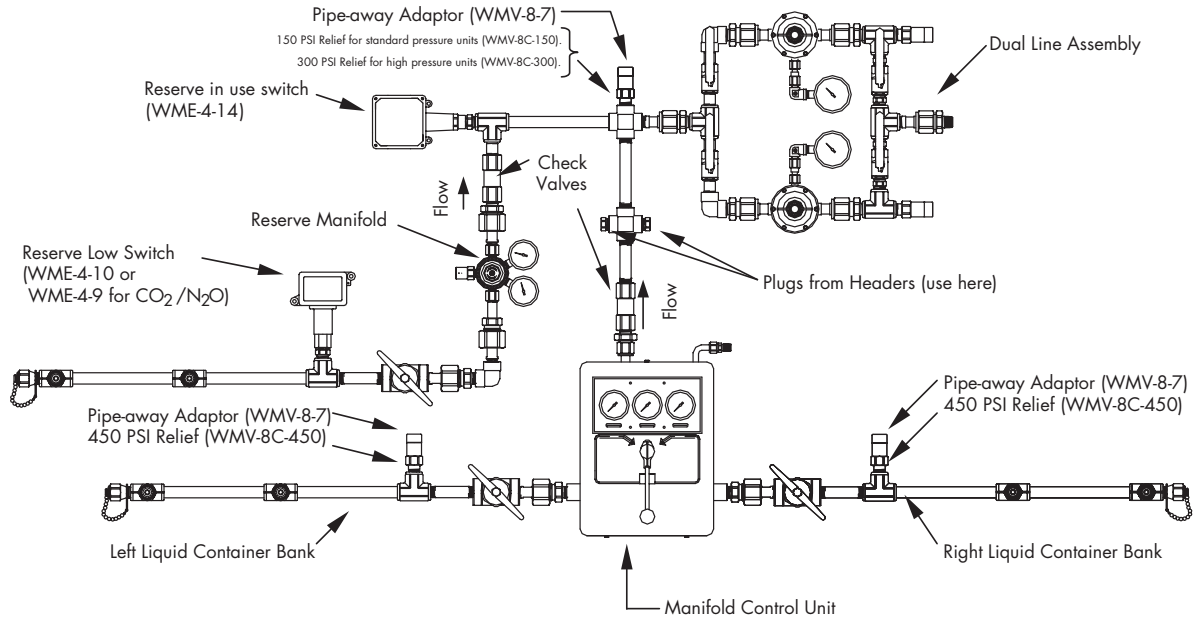

MODEL: MLC(HP)-W-X-YL

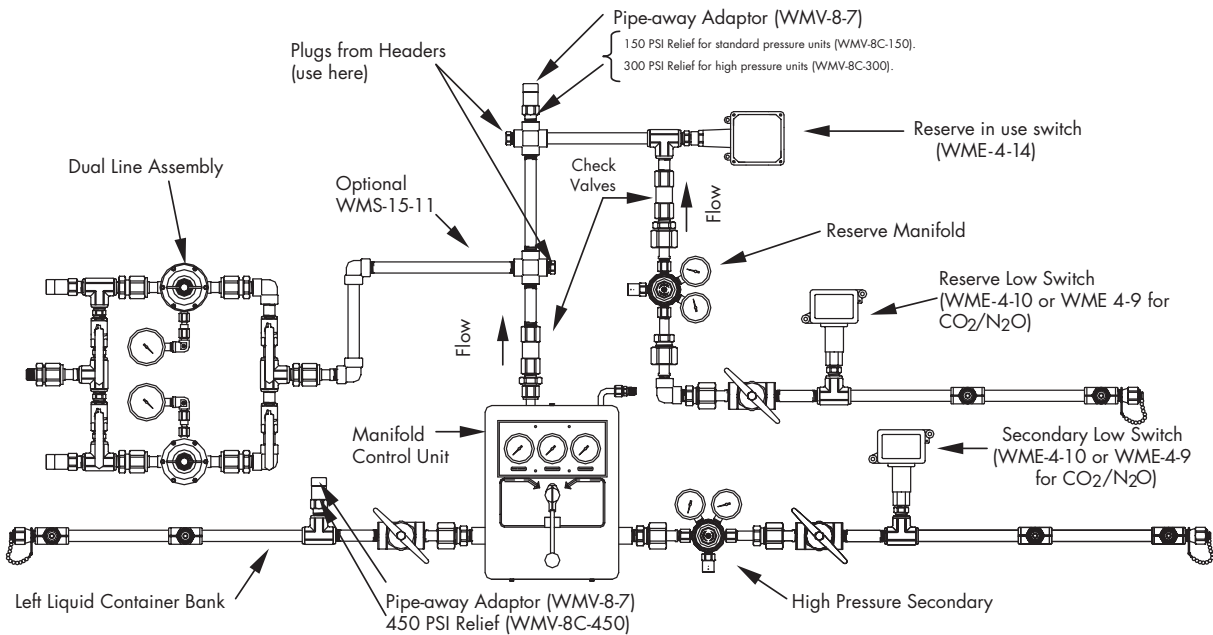

MODEL: Hybrid MLC(HP)-W-X-Y-Z

NOTE: Optional WMS-15-11 used in this assembly.

*Other configurations possible

MCLA

Western Innovator MCLA high pressure reserve manifolds are specifically designed for healthcare facilities requiring an emergency back-up gas supply to meet NFPA-99 2012 requirements. (See page 23 for drawings)

specifications

- 1/2" plugged tee, for "reserve low" pressure switch (Western part number WME-4-10 and adaptor WMS-1-97)
- Maximum inlet pressure: 3000 psig
- Adjustable regulator
 - MCLA 20-160 psig
 - MCLAHP 40-300 psig
- Manifold outlet: 1/2" NPT male
- Oxygen Pigtails: NFPA 99 compliant, rigid copper, with check valves
Other Gas Pigtails: NFPA 99 compliant, 24" flexible stainless steel with check valves



Design Lengths

TOTAL NO. OF CYLINDERS	3	4	5	6	7	8	9
MCLA- Standard (10" Centers) Overall Manifold Length	4'-5" (1.35m)	5'-3" (1.60m)	6'-1" (1.85m)	7'-0" (2.13m)	7'-10" (2.39m)	8'-8" (2.64m)	9'-6" (2.90m)
MCLA- Staggered (5" Centers) Overall Manifold Length	3'-2" (0.97m)	3'-7" (1.09m)	4'-0" (1.22m)	4'-5" (1.35m)	4'-10" (1.47m)	5'-3" (1.60m)	5'-8" (1.73m)
MCLA- Vertical Crossover (10" Centers) Overall Manifold Length	N/A	3'-7" (1.09m)	N/A	4'-5" (1.35m)	N/A	5'-3" (1.60m)	N/A

HOW TO ORDER

CONTROL TYPE (W)	GAS SERVICE (X)	# OF CYL'S (Y)	HEADER CONFIGURATION (Z)
MCLA (20 to 160 psig)	(2) Breathing Air (4) Carbon Dioxide (7) Nitrogen	CGA-346 CGA-320 CGA-580	Blank - Standard 10" on Center S - Staggered 5" on Center V - Vertical Crossover 10" on Center
MCLAHP (40 to 300 psig)	(8) Nitrous Oxide (9) Oxygen	CGA-326 CGA-540	

DUAL LINE REGULATOR ASSEMBLIES

Western dual line regulator assemblies are designed for use in medical piping systems to meet NFPA-99 requirements (See page 23 for drawings).

The dual line regulator assembly is intended for breathing air, oxygen, nitrous oxide medical breathing mixtures, nitrogen and carbon dioxide applications.

specifications

- Maximum inlet pressure: 350 psig
- Outlet pressure ranges: 30–70 psig or 70–200 psig
- Inlet port: 1/2" NPT male
- Outlet port: 1/2" NPT male
- Relief valve outlet port: 1/2" NPT female

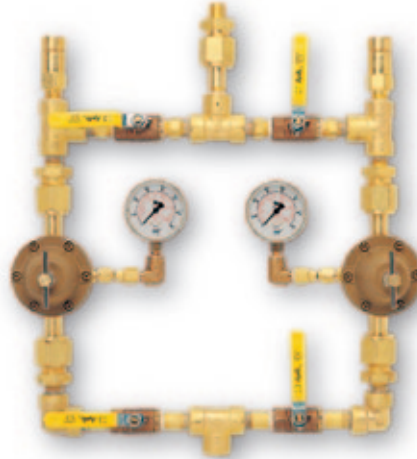

DLA-4

Ordering Information

PART NUMBER	SIZE	DESCRIPTION	RELIEF VALVE SETTING
DLA-4	1/2" NPTM	Dual line regulator for N ₂ , N ₂ O, CO ₂ , or O ₂ , 30–70 psig delivery pressure	75 psig
DLA-5	1/2" NPTM	Dual line regulator for Nitrogen 70–200 psig delivery pressure	250 psig



HEALTHCARE MANIFOLD REPLACEMENT PIGTAILS NFPA 99 COMPLIANT

FHM2, HGM2, AGM2, MCLA, MLC (high pressure side & reserve manifold)

GAS	24"	36"
Breathing Air (CGA 346)	PFP-346CV-24	PFP-346CV-36
Carbon Dioxide (CGA 320)	PFP-320CV-24	PFP-320CV-36
Nitrogen (CGA 580)	PFP-92CV-24	PFP-92CV-36
Nitrous Oxide (CGA 326)	PFP-326CV-24	PFP-326CV-36
Oxygen (CGA 540)	WPR-63CW	WPR-63CW-36

MLC (liquid cylinder side, available in 72" length only)

GAS	72"
Carbon Dioxide (CGA 320)	P-320-72-TW375
Nitrogen (CGA 580)	P-580-72-TW375
Nitrous Oxide (CGA 326)	P-326-72-TW375
Oxygen (CGA 540)	P-540-72-TW375



Western Innovator High Purity, Specialty Gas Manifolds offer you:

- Flexibility to meet your customer's individual manifold needs in today's competitive market.
- The best value and highest quality in the industry.
- Systems that are designed and tested to pass a leak test of 2×10^{-6} scc/sec. and are cleaned and tested for the indicated gas service.
- 1 year limited warranty.

SPECIALTY GAS MANIFOLDS

WESTERN INNOVATOR'S HIGH PURITY SPECIALTY GAS MANIFOLDS

Western Innovator High Purity Specialty Gas Manifolds are designed and manufactured to meet the specific requirements of high purity gas applications including laser gas, gas chromatography, mass spectrometry and atomic absorption.

HBAC2

Western Innovator HBAC2 manifolds are designed and manufactured for high-purity gas delivery applications requiring uninterrupted gas flow and greater cylinder capacities. User friendly and easy to operate, a simple rotation of the control knob resets the unit.

Factory-set functional components are protected inside a tamper-resistant case. A self-contained alarm system clearly indicates the system status. A green light means the system is ready for service. A red light alerts the user that the unit has changed over. Dry contacts in the unit's power supply box allow connection to remote alarms systems.

specifications

- High Purity Automatic Analog System
- CSA Approved Power Source included
- Stainless steel diaphragm regulators
- Helium leak rate integrity: 2×10^{-6} scc/sec
- Maximum inlet pressure: 3000 psig (2000 psig for CO₂ & N₂O systems)
- Maximum flow rate:

HBAC2	250 scfh
Acetylene	20 scfh
- Delivery pressure range:

HBAC2	30–100 psig
Acetylene	0–15 psig
HBAC2HP	50–200 psig
- Manifold outlet: 1/4" OD tube fitting
- 1/2" Brass, silver brazed headers
- 24" flexible stainless steel lined pigtailed with check valves
- Relief Valve outlet port: 1/2 NPT female
- Fuel gas units do not include visual alarm, power supply, or any electrical components. Fuel gas alarm kits are available as an option
- Connects to Remote Alarm systems (Up to 3 amps 30 VDC or 2 amps 250 VAC)



HBAC series

HOW TO ORDER

Specify: Control Type (V)–Service (W)–Number of Cylinders (X)		
Example: HBAC2-5-6 = Model HBAC2, Helium service, 5 cylinders		
CONTROL TYPE (V)	GAS SERVICE (W)	# OF CYL'S (X)
HBAC2 (30–100 psig)	(1) Acetylene (POL) CGA-510 (1A) Acetylene (Commercial) CGA-300	
HBAC2HL (30–100 psig) (includes 500 scfh heater)	(2) Compressed Air CGA-346 (2A) Zero Air CGA-590 (3) Argon CGA-580 (4) Carbon Dioxide CGA-320	
HBAC2HP (50–200 psig)	(5) Helium CGA-580 (6) Hydrogen CGA-350 (6A) Argon/Methane Mixtures CGA-350 (7) Nitrogen CGA-580 (8) Nitrous Oxide CGA-326 (9) Oxygen CGA-540	

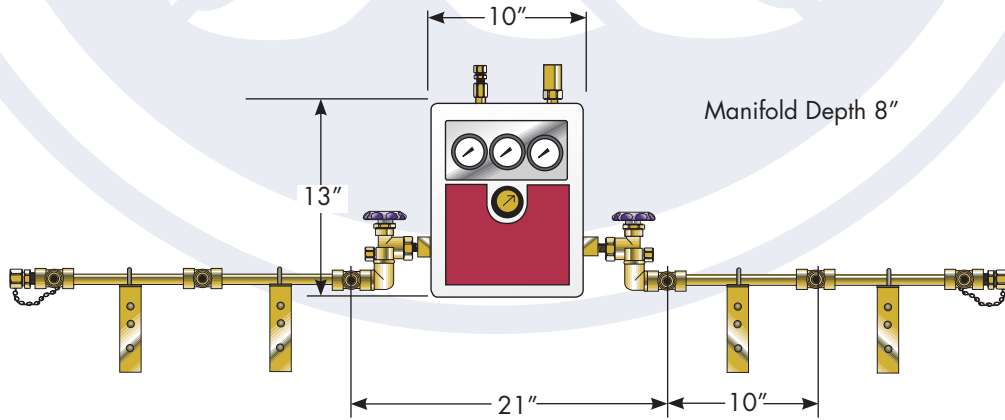

Example: HBAC2-9-6 = Oxygen (9=CGA-540) Manifold for 6 Cylinders

Design Lengths HBAC2

TOTAL NO. OF CYLINDERS	2	4	6	8	10	12	16	20
HBAC2 Standard (10" Centers) Overall Manifold Length	2'-3" (.7m)	3'-11" (1.2m)	5'-7" (1.7m)	7'-3" (2.21m)	8'-11" (2.72m)	10'-7" (3.23m)	13'-11" (4.24m)	17'-3" (5.26m)
HBAC2 Staggered Design (5" Centers) Overall Manifold Length	2'-3" (.7m)	3'-1" (.94m)	3'-11" (1.2m)	4'-9" (1.45m)	5'-7" (1.7m)	6'-5" (1.96m)	8'-1" (2.46m)	9'-9" (2.97m)
HBAC2 Vertical Crossover (10" Centers) Overall Manifold Length	N/A	2'-3" (.7m)	N/A	3'-11" (1.2m)	N/A	5'-7" (1.7m)	7'-3" (2.21m)	8'-11" (2.72m)
HBAC2 Standard (13" Centers) (Acetylene) Overall Manifold Length	2'-3" (.7m)	4'-5" (1.35m)	6'-7" (2m)	8'-9" (2.7m)	10'-11" (3.3m)	13'-1" (4m)	17'-5" (5.31m)	21'-9" (6.63m)
HBAC2 Staggered Design (10" Centers) (Acetylene) Overall Manifold Length	2'-3" (.7m)	3'-4" (1m)	4'-5" (1.35m)	5'-6" (1.67m)	6'-7" (2m)	7'-8" (2.34m)	9'-10" (3.00m)	12'-9" (3.66m)

Cylinders (X)-Header Configuration (Y)-Mounting (Z)

for 6 total cylinders 10 inches on center, wall mounted.

	HEADER CONFIGURATION (Y)	MOUNTING (Z)
	BLANK -Standard 10" on Center 13" on Center for Acetylene & LPG S -STAGGERED 5" on Center 6.5" on Center for Acetylene & LPG V -VERTICAL CROSSOVER Standard 10" on Center or 13" on Center for Acetylene & LPG C -CROSSOVER (Floor Mount Only) Standard 10" on Center or 13" on Center for Acetylene & LPG U-Shaped -Drawing Required L-Shaped -Drawing Required	BLANK = Wall mount F = Floor mounted



LAB

Western Innovator LAB Series manifolds are designed to regulate and deliver an uninterrupted supply of gas for High Purity applications. The LAB Series are designed with features providing

automatic changeover from a single Primary gas cylinder to a single Reserve gas cylinder, without the loss of delivery pressure. A simple rotation of the control knob resets the unit.

specifications

- High Purity Automatic Analog System
- Stainless steel diaphragm regulators
- Packless diaphragm valves
- Maximum inlet pressure: 3000 psig (2000 psig for CO₂ & N₂O systems)
- Maximum flow rate:

Most gases	250 scfh
CO ₂	35 scfh
N ₂ O	35 scfh
- Delivery pressure range:

LAB 1/2	30–100 psig
Acetylene	0–15 psig
LAB 1/2 HP	50–200 psig
- Manifold outlet: 1/4" OD tube
- Relief valve outlet: 1/2" OD tube
- Rigid copper pigtails with check valves
- HPF flexible pigtails optional
- Vent Valves included (LAB1 models only)
- 1 X 1 system only



LAB1 Model Shown

HOW TO ORDER

Specify: Control Type (V)–Service (W)–Mounting (X)		
Example: LAB1-3 = Model LAB1, Argon service		
CONTROL TYPE (V)	GAS SERVICE (W)	MOUNTING (X)
LAB 1 (30–100 psig) Acetylene (0–15 psig) LAB 1HP (50–200 psig)	(1) Acetylene (POL) (1A) Acetylene (Commercial) (2) Air (2A) Zero Air	CGA-510 CGA-300 CGA-346 CGA-590
LAB 2 (30–100 psig) Acet (0–15 psig) LAB 2HP (50–200 psig)	(3) Argon (4) Carbon Dioxide (5) Helium (6) Hydrogen (7) Nitrogen (8) Nitrous Oxide (9) Oxygen	CGA-580 CGA-320 CGA-580 CGA-350 CGA-580 CGA-326 CGA-540
		BLANK = Wall mount F = Floor mounted

LAB series

HBCS

The Western Innovator HBCS automatic manifold is designed for High Purity gas applications where a constant uninterrupted supply of gas is critical while maintaining gas purity. The HBCS may be configured to meet almost any lab application requirements. The compact manifold headers

allow multiple gas cylinders, up to 4 per bank, to supply gas to the manifold. In order to maintain system purity and provide isolation, the headers also include a packless diaphragm valve. All systems include an adjustable outlet regulator with a choice of outlet pressure ranges.

specifications:

- High Purity Automatic Analog System
- Chrome plated brass bar stock regulators
- 316L Stainless steel diaphragms
- Designed for gas purity levels up to grade 5.5 (99.9995%)
- Outlet Pressure Ranges: 0–15, 0–50, 0–125 psig
- Maximum inlet pressure 3000 psig
- Switchover pressure
R to L–180 psig
L to R–160 psig
- PTFE seats and seals
- 10 micron sintered bronze filters

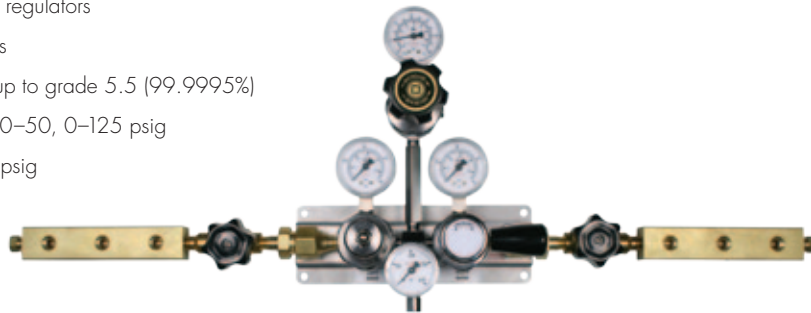

Manifold Features

- 180 degree lever indicates active cylinder side
- 2" dual scale inlet pressure and outlet pressure gauges
- 1-3/4" intermediate pressure gauge
- External threaded relief valve
- Stainless steel wall mounting panel

Header Features

- Compact design
- Universal left or right
- Includes a packless diaphragm valve
- Designed to accept up to 4 pigtails
- Wall mounting brackets included
- 1/4" NPT female inlets, 2 plugged
- CGA specific outlet adaptor supplied

Pigtail Features

- 1/4" Stainless steel inner core
- Stainless steel outer sleeve
- Check valve on inlet
- CGA inlet / 1/4" NPT outlet
- 24" in length
- Pressure rating–3000 psig

HOW TO ORDER

(1) Select Changeover unit according to desired outlet pressure (2) Select Header Kit according to CGA (gas)*-Ordered Separately (sold as pairs only) (3) Select Pigtails according to CGA (gas)-HPF style-Ordered Separately					
(1) CHANGEOVER		GAS SERVICE		(2) HEADER KIT	(3) PIGTAILS
HBCS-015 (0–15 psig)		(2) Air	CGA-346	HBCSH-2	HBCSP-2
HBCS-050 (0–50 psig)		(2A) Zero Air	CGA-590	HBCSH-2A	HBCSP-2A
HBCS-125 (0–125 psig)		(4) Carbon Dioxide	CGA-320	HBCSH-4	HBCSP-4
		(6) Hydrogen	CGA-350	HBCSH-6	HBCSP-6
		(7) Nitrogen, Argon, Helium	CGA-580	HBCSH-7	HBCSP-7
		(8) Nitrous Oxide	CGA-326	HBCSH-8	HBCSP-8
		(9) Oxygen	CGA-540	HBCSH-9	HBCSP-9

*No header kit is needed for a standard 1 x 1 configuration

HBCS series



CS3000

The CS3000 Series Automatic Changeover Stations are designed to provide a continuous supply of high purity gases. The system automatically changes from a depleted bank of cylinders in service to the full reserve bank without an interruption of gas supply. A simple

rotation of the primary bank lever resets the unit. The standard outlet regulator maintains a constant line pressure, even during the changeover process. The optional remote alarm box indicates when the pressure of each bank is either normal or low.

specifications

- High Purity Automatic System
- Available in Brass or Stainless steel construction
- Stainless Steel Diaphragms in all Regulators
- Maximum Inlet Pressure: 3000 psig
- Available in a variety of outlet pressures
- Manifold outlet: stainless steel; 1/4" OD Tube
- Master shut off valve standard
- Choice of pigtail inner core materials
pigtails include check valves

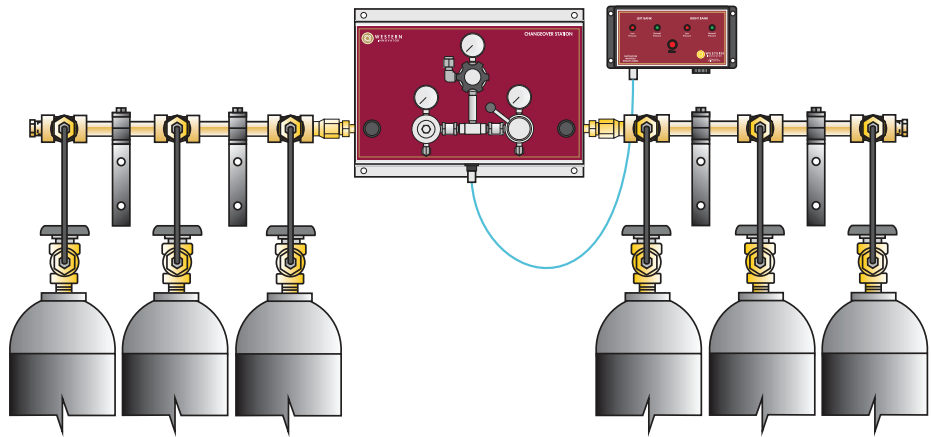

Model Shown: CS3000-7-150-B1-3-3-NH-W-RA2

HOW TO ORDER

CS3000	Gas	Outlet Pressure	Regulator	Left Bank	Right Bank	Pigtails	Options
Standard series 3000 psi = CS3000	Air = 2 Helium = 5 Hydrogen = 6 Nitrogen = 7 Most specialty gases can be specified including acetylene and LPG	1-15 = 15 2-50 = 50 10-150 = 150 30-500 = 500	Brass = B1 regulators Stainless = B2 steel regulators	No. of cylinders (maximum 6 per side)		Thermoplastic = NH fittings PTFE core, = TH brass fittings, S/Steel braid, All stainless = SH steel	Standard = RA2 alarm Vent Valve = VV Diaphragm = DV valve Electric = ETH trim heater

SA3350

The SA3350 Series Semi-Automatic Changeover Stations are designed to provide a back-up gas supply from high pressure gas cylinders where liquid cylinders are the primary source of high purity gases. The system activates the reserve bank when the liquid cylinder pressure drops below the preset pressure and deactivates when the liquid cylinder pressure rises

above the preset pressure. Monitoring or operator adjustments are not required during the reserve bank activation or deactivation. The standard outlet regulator maintains constant line pressure even during the changeover process. The optional remote alarm box indicates when the pressure of each bank is either normal or low.

specifications

- High Purity Automatic System.
- Available in Brass or Stainless steel construction
- Stainless Steel Diaphragms in all Regulators
- Maximum Inlet Pressure: L:3000 psig / R:350 psig
- Available in a variety of outlet pressures
- Manifold outlet: SS-1/4" OD Tube
- Choice of pigtail inner core materials
pigtails include check valves

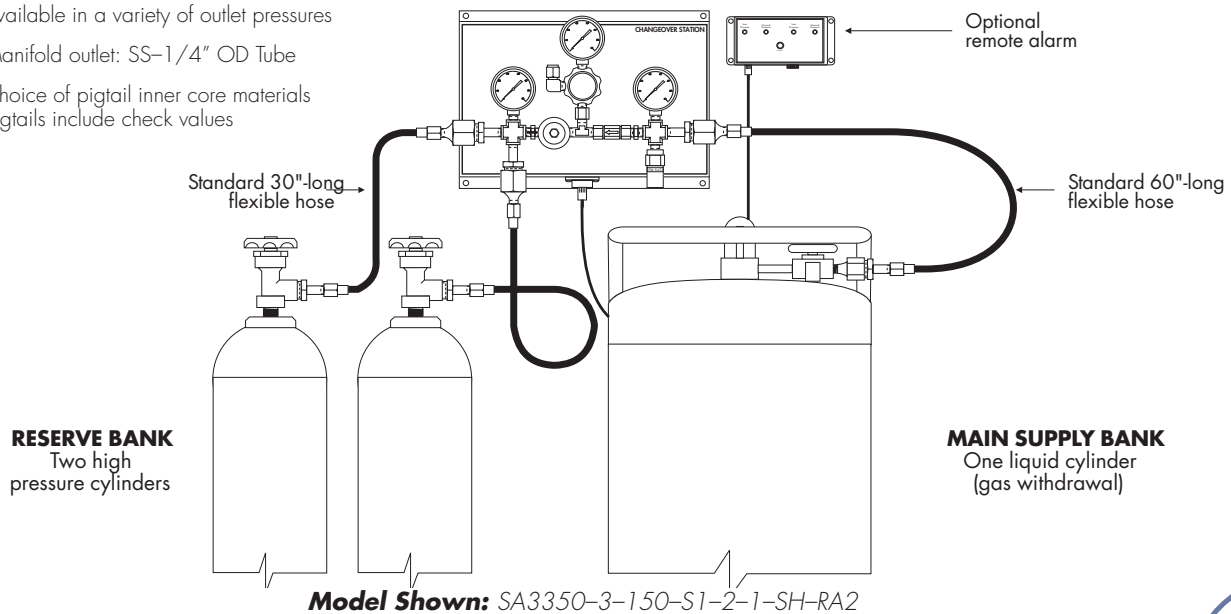

HOW TO ORDER

SA3350	Gas	Outlet Pressure	Regulator	H.P.	Liquid	Pigtails	Options
Standard = SA 3350 series	Argon = 3	1-15 = 15	Brass = B1 regulators	(Max. 6)	(Max. 2)	Thermoplastic = NH (Nylon) steel fittings	Standard = RA2 alarm
3000 psi (Reserve)	Carbon = 4	2-50 = 50	Stainless = S1 steel regulators			PTFE core, = TH brass fittings, S/Steel braid, All stainless = SH steel	Vent Valve = VV
350 psi (Liq. Cyl.)	Nitrogen = 7	5-100 = 100					
	Oxygen = 9	10-150 = 150					

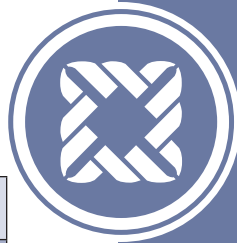

MC3000

The MC3000 Series Manual Changeover Stations allow manual switching between a primary cylinder and a reserve cylinder. By closing the depleted cylinders isolation valve and opening the reserve (full) isolation valve, you perform cylinder changeouts

without gas supply interruption. The check valves in the flexible hoses prevent back flow from the full to the empty cylinder. The optional remote alarm will provide an audible and visual warning when a cylinder is near depletion.

specifications

- High Purity Manual Protocol Station
- Available in Brass or Stainless steel construction
- Stainless Steel Diaphragms in all Regulators
- Maximum Inlet Pressure: 3000 psig
- Available in a variety of outlet pressures
- Gas outlet: 1/4" NPTF

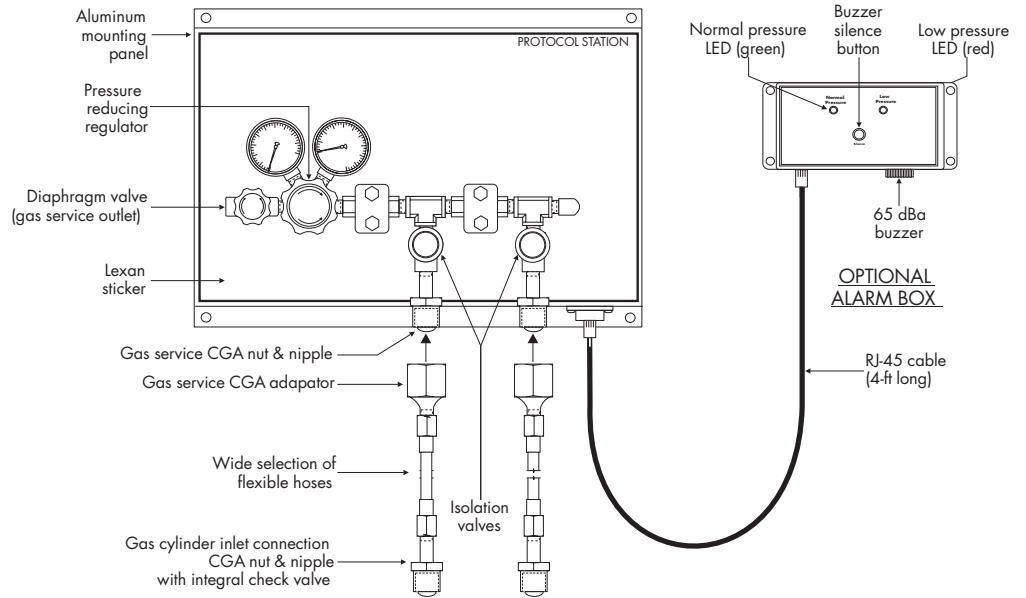

Model Shown: MC3000-5-150-B1-SH-RA1

HOW TO ORDER

MC3000	Gas	Outlet pressure	Regulator	Pigtails	Options
Standard series 3000 psi = MC3000	Air = 2 Helium = 5 Hydrogen = 6 Nitrogen = 7	1-15 = 15 4-75 = 75 10-150 = 150 30-500 = 500	Brass/ single-stage = B1 (standard regulator) Brass/ Two-stage = B2 SS/ single-stage = S1 SS/ two-stage = S2	Thermoplastic (Nylon) = NH steel fittings PTFE innercore, = TH SS braid, brass fittings Stainless steel innercore, = SH overbraid & fittings	Standard = RA1 alarm Vent Valve = VV
	Most specialty gases can be specified including acetylene and LPG				

MC, PS series

PS3000

The PS3000 Series Protocol Station is a convenient and safe way to panel mount any type of regulator, its flexible hose and an optional remote alarm. This regulator panel concept eases cylinder changeouts, prevents regulator damage, and allows the addition

of options such as vent valves and alarms. The check valve in the flexible hose minimizes the introduction of air and airborne contaminants into the system. The optional remote alarm will provide an audible and visual warning when the cylinder is near depletion.

specifications

- High Purity Manual Protocol Station.
- Available in Brass or Stainless steel construction
- Stainless Steel Diaphragm Regulator
- Maximum Inlet Pressure: 3000 psig
- Available in a variety of outlet pressures
- Gas outlet: 1/4" NPT female

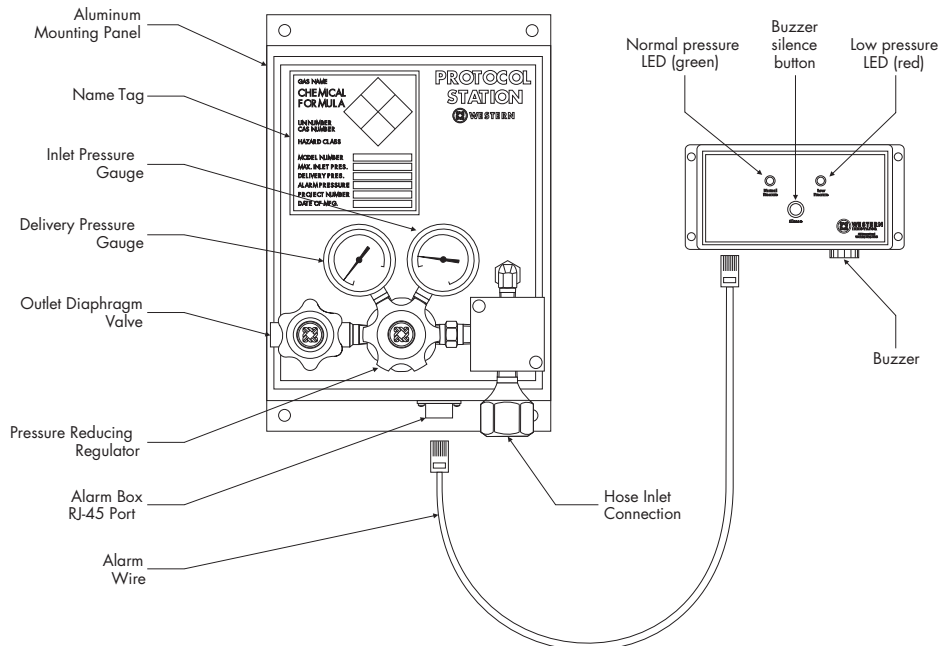

Model Shown: PS3000-5-150-B1-SH-WV-RA1

HOW TO ORDER

PS3000	Gas	Outlet pressure	Regulator	Pigtails	Options
Standard series 3000 psi = PS3000	Air = 2 Helium = 5 Hydrogen = 6 Nitrogen = 7	1-15 = 15 4-75 = 75 10-150 = 150 30-500 = 500	Brass/ single-stage = B1 (standard regulator)	Thermoplastic (Nylon) = NH steel fittings	Standard = RA1 alarm
Optional series 6000 psi = PS6000	Most specialty gases can be specified including acetylene and LPG		Brass/ Two-stage = B2 SS/ single-stage = S1 SS/ two-stage = S2	PTFE innercore, = TH SS braid, brass fittings Stainless steel innercore, = SH overbraid & fittings	Vent Valve = WV



SPECIALTY GAS MANIFOLD REPLACEMENT PIGTAILS

HBAC2, LAB1, LAB2, (Stainless Steel Flexible)

GAS	24"	36"
Acetylene (CGA 510)	HPF-15CVFA-24	HPF-15CVFA-36
Acetylene (CGA 300)	HPF-16CVFA-24	HPF-16CVFA-36
Air (CGA 346)	HPF-346CV-24	HPF-346CV-36
Zero Air (CGA 590)	HPF-590CV-24	HPF-590CV-36
Argon (CGA 580)	HPF-92CV-24	HPF-92CV-36
Carbon Dioxide (CGA 320)	HPF-320CV-24	HPF-320CV-36
Helium (CGA 580)	HPF-92CV-24	HPF-92CV-36
Hydrogen (CGA 350)	HPF-83CV-24	HPF-83CV-36
Argon/Methane (CGA 350)	HPF-83CV-24	HPF-83CV-36
Nitrogen (CGA 580)	HPF-92CV-24	HPF-92CV-36
Nitrous Oxide (CGA 326)	HPF-326CV-24	HPF-326CV-36
Oxygen (CGA 540)	HPF-63CV-24	HPF-63CV-36

HBAC2, LAB1, LAB2, (Rigid Copper)

GAS	24"	36"
Acetylene (CGA 510)	WPR-15CVFA	N/A
Acetylene (CGA 300)	WPR-16CVFA	N/A
Air (CGA 346)	WPR-1340CV	N/A
Zero Air (CGA 590)	WPR-93CW	N/A
Argon (CGA 580)	WPR-92CW	N/A
Carbon Dioxide (CGA 320)	WPR-320CV	N/A
Helium (CGA 580)	WPR-92CW	N/A
Hydrogen (CGA 350)	WPR-83CW	N/A
Nitrogen (CGA 580)	WPR-92CW	N/A
Nitrous Oxide (CGA 326)	WPR-1320CV	N/A
Oxygen (CGA 540)	WPR-63CW	WPR-63CW-36

HBCS

GAS	24"
Air (CGA 346)	HBCSP-2
Zero Air (CGA 590)	HBCSP-2A
Carbon Dioxide (CGA 320)	HBCSP-4
Hydrogen (CGA 350)	HBCSP-6
Argon, Helium, Nitrogen (CGA 580)	HBCSP-7
Nitrous Oxide (CGA 326)	HBCSP-8
Oxygen (CGA 540)	HBCSP-9



ACCESSORIES

MOUNTING ACCESSORIES, GAS HEATERS

CYLINDER BRACKETS

Wall mount cylinder holders are an essential accessory to all manifolds. For safe containment of cylinders not greater than 9" – 12" in diameter. Equipped with plated safety chain or strap. Painted black.

PART NUMBER	DESCRIPTION
WB1	One cylinder wall bracket with chain
WB2	Two cylinder wall bracket with chain
SWB-1-1	One cylinder wall bracket with strap
SWB-2-1	Two cylinder wall bracket with strap
SWB-3-1	Three cylinder wall bracket with strap
SWB-4-1	Four cylinder wall bracket with strap



WB2 Double Bracket



SWB-3-1 Bracket

MANIFOLD BRACKET & MOUNTING HARDWARE

L-shaped steel wall bracket, painted black, 5/16" holes pre-drilled. Dimensions: 1-1/2" wide, 5-3/4" high and 4" deep. Zinc plated steel U-bolt, inside diameter is 1", center to center width is 1-3/8". Center line to mounting surface is 2-1/2". Includes strap and nuts.

PART NUMBER	DESCRIPTION
WMC-6-2	Bracket
WMC-6-13B	U-bolt, Strap and Nuts

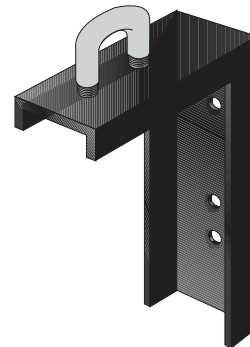

GAS HEATERS

Western's automatic gas heaters are designed to prevent regulator freeze-up and assure uniform temperature with constant gas flow at all times. All units are completely automatic and can be used with pressure up to 3000 psig. Highly recommended for use with Carbon Dioxide and Nitrous Oxide when withdrawal rates exceed 35 scfh. Requires 115 volts (AC).

PART NUMBER	DESCRIPTION	GAS SERVICE	CAPACITY
WME-3-4	Gas Heater	Carbon Dioxide (CGA-320)	1,000 scfh
WME-3-7	Gas Heater	Nitrous Oxide (CGA-326)	1,000 scfh
WHS-11	Manifold Adapter	Carbon Dioxide (CGA-320)	
WHS-12	Manifold Adapter	Nitrous Oxide (CGA-326)	

Note: To connect the heater to most Western manifold headers, manifold adapter WHS-11 or WHS-12 required.



FUEL GAS ACCESSORIES

FLASHBACK ARRESTORS

Dry and hydraulic flashback arrestors are designed for use on Acetylene or Fuel Gas manifold systems, as well as station drops, to protect the main fuel gas supply from the dangers of reverse flow and flashbacks. A safety relief valve is included with each arrestor and is installed on the outlet side. In the event excessive pressure does occur, the gas is vented away to a safe location. All models are UL listed.

VENT PART NUMBER	GAS	CAPACITY SCFH	INLET/OUTLET	RELIEF VALVE SET PRESSURE (psig)
TYPE: HYDRAULIC				
WEM-1-17	Acetylene	300	1" NPT	20 psig
WEM-1-36	LPG/Hydrogen	300	1" NPT	40 psig
WEM-1-22	Floor Stand			
TYPE: DRY				
WEM-1-25	Acetylene	300	1/2" NPT	20 psig
WEM-1-26	LPG/Hydrogen	300	1/2" NPT	35 psig

Note: Flashback arrestor fluid not included with hydraulic arrestor. Available from most industrial supply stores. (Use Ethleneglycol).



FUEL GAS SAFETY KITS

Fuel gas safety kits are available as an option for use with any of Western's industrial fuel gas manifolds. The fuel gas safety kit includes either a dry or hydraulic flashback arrestor and the proper piping to connect the flashback arrestor to your Western manifold.

MANIFOLD TYPE	MD SERIES	BI SERIES	MS SERIES	FLOW CAPACITY	RELIEF VALVES
Acetylene/Hydraulic	DM-FKA	BI-FKA	MS-FKA	300 scfh	20 psig
LPG/H ₂ /Hydraulic	DM-FK	BI-FK	MS-FK	300 scfh	40 psig
LPG/H ₂ /Dry	DM-FKD	BI-FKD	MS-FKD	300 scfh	35 psig

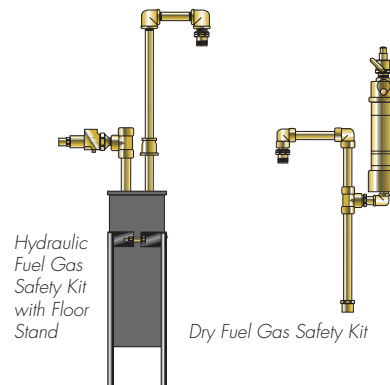

FUEL GAS ALARM KITS

These kits are designed specifically for Western Manifold units for use with Acetylene, Hydrogen or Liquefied Fuel Gases. These kits are cleaned, tested and built following National Fire Protection Association, Compressed Gas Association, Canadian Standards Association and OSHA guidelines. Each fuel gas alarm kit consists of an explosion proof (Class 1 Division 2) pressure switch, a 24 VAC transformer assembly (WMS-9-25C), an audio visual alarm (BIA-3), rated NEMA 1, and all fittings required for installation. These alarm kits will signal to a remote location that the manifold primary supply bank has been depleted and the secondary supply is now in use.

PART NUMBER	DESCRIPTION
FGAK-A	BI-Acetylene models
FGAK-H	BI-Hydrogen models
FGAK-L	BI-LPG models
HFGAK-A	HBAC2-Acetylene models
HFGAK-H	HBAC2-Hydrogen models



PRESSURE SWITCHES, REMOTE ALARMS AND POWER SUPPLIES

PRESSURE SWITCHES

Designed for use with gas pressure manifolds to activate remote alarm systems. Operates when cylinder/line pressure is below minimum pressure setting. High/Low switches have two activation points. Available for explosion proof or general purpose service. Electrical rating for all switches is SPDT 15 amps 24/125/250/480 VAC resistive. CSA approved. Pressure port connection 1/4" NPT female.



Specifications and Ordering Information Guidelines

PART NUMBER	DESCRIPTION	PRESSURE RANGE (psig)	MAXIMUM INLET (psig)	WETTED MATERIALS	ENCLOSURE CLASSIFICATIONS	ELECTRICAL CONNECTION
WME-4-5	Explosion Proof	30-300	800	S.S. Bellows	NEMA 4, 7, 9, IP66	3/4" NPT
WME-4-6	Explosion Proof	5-50	75	Brass Bellows	NEMA 4, 7, 9, IP66	3/4" NPT
WME-4-9	General Purpose	100-1000	10,000	S.S. Piston & BUNA "N" oring	NEMA 4	1/2" NPT
WME-4-10	General Purpose	200-3000	10,000	S.S. Piston & BUNA "N" oring	NEMA 4	1/2" NPT
WME-4-13	High/Low Switch	0-300	350	Phosphor Bronze Bellows	NEMA 4	7/8" Dia. Knockout
WME-4-14	General Purpose	20-200	250	Phosphor Bronze Bellows	NEMA 4	1/2" NPT & 7/8 Dia. Knockout
WME-4-15	High/Low Switch	0-100	125	Brass Bellows	NEMA 4, 7, 9, IP66	7/8" Dia. Knockout
WME-4-16	General Purpose	20-200	250	316 S.S. Bellows	NEMA 4	1/2" NPT Female
WME-4-17	General Purpose	100-1700	2500	316 S.S. Bellows	NEMA 4	1/2" NPT Female
WME-4-18	High/Low Switch	20-200	250	316 S.S. Bellows	NEMA 4	7/8" Dia. Knockouts
WME-4-20	High/Low Explosion Proof	0-100	125	Brass Bellows	NEMA 4, 7, 9, IP66	3/4" NPT Female

Note: Switches may be wired "normally open" or "normally closed".

REMOTE ALARM PANELS

Visual Alarm Panel - Contains green LED to indicate "service" side is in use and red LED to indicate control unit has switched to "secondary" side. Audio/Visual Alarm Panel - Contains red and green alarm lights and buzzer with "squench" button. Green light remains illuminated while "service" bank is in use. When "service" bank is exhausted, green light is extinguished, red light is lighted plus buzzer, rated 75 decibels within 100 centimeters, is activated to ensure notice of the alarm conditions. A touch of the squench button silences the buzzer, but the red alarm light will remain illuminated until the exhausted bank has been replaced. Two Gas Audio/Visual Alarm Panel - As above, but warning alarm lights and buzzer for two gases in a single box, i.e. Oxygen and Nitrogen, etc.

All panels may be for either exposed or flush mounting. Available in 24 VAC service only. Alarm dimensions: 4-3/4"H x 2-9/16" W x 1-5/8"D. For open style manifolds, a 115/24 VAC power supply part number WMS-9-25C is required.



Model BIA-3

PART NUMBER	DESCRIPTION
BIA-1	Visual Alarm, 24 VAC
BIA-2	Two Gas Audio/Visual Alarm, 24 VAC
BIA-3	Audio/Visual Alarm, 24 VAC

POWER SUPPLIES

Utilized with remote alarm panels, reduces 115 VAC to 24 VAC. A circuit board in the power supply isolates remote alarms regardless of voltage (up to 3 amps 30 VDC or 2 amps 250 VAC). Dimensions: 6-1/4" x 4". Rated NEMA 3R, CSA approved.



PART NUMBER	DESCRIPTION
WMS-9-25C	For use with SD, MS, MD, and LA
8570D	For use with BI, LC, HBAC2 cabinet style manifolds

STATION DROPS

STATION DROPS

Western station drops are equipped with an in-line shut-off valve, drip leg and outlet cap and chain. All drops are labeled for the indicated gas service. No assembly required. Available in 1/2" or 3/4"; single or double outlet. Double outlet station drops shipped complete with shut-off valves. All single outlet drops for fuel gas or oxidizer gas service equipped with a check valve.

GAS SERVICE (X)	OUTLET CONNECTION
(1) Acetylene	7/8"-14 LH
(2) Compressed Air	9/16"-18 RH
(3) Argon	5/8"-18 RH
(4) Carbon Dioxide	5/8"-18 RH
(5) Helium	5/8"-18 RH
(6) Hydrogen	7/8"-14 LH
(7) Nitrogen	5/8"-18 RH
(8) Nitrous Oxide	7/8"-14 RH
(9) Oxygen	7/8"-14 RH
(10) LPG	7/8"-14 LH

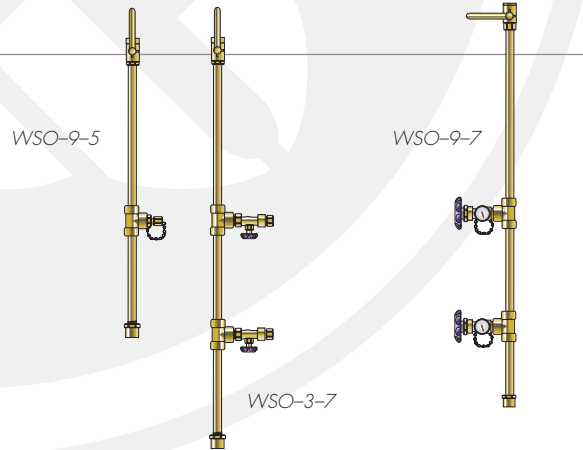

How To Order: Insert (X) = gas service

MODEL #	OUTLET	LENGTH
WSO-(X)-5	1/2" Single outlet	25"
WSO-(X)-6	3/4" Single outlet	25"
WSO-(X)-7	1/2" Double outlet	35"
WSO-(X)-8	3/4" Double outlet	35"

LINE STATION REGULATORS

The Western line station regulators utilize a large diaphragm for high sensitivity and provide extremely accurate delivery pressure.

Note: Maximum inlet pressure 200 psig.

MODEL	APPLICATION	DELIVERY PRESSURE	CAPACITY SCFH	INLET CONNECTION	OUTLET CONNECTION
WSR-1-1	Oxygen	0-125 psig	760	7/8"-14 RH, CGA-024	9/16"-18 RH, CGA-022
WSR-1-2	Acetylene	0-15 psig	420	7/8"-14 LH, CGA-025	9/16"-18 LH, CGA-023
WSR-1-3	Fuel Gases	0-50 psig	640	7/8"-14 LH, CGA-025	9/16"-18 LH, CGA-023
WSR-1-5	Oxygen	0-100 psig	475	7/8"-14 RH, CGA-024	9/16"-18 RH, CGA-022
WSR-1-6	Oxygen	0-200 psig	475	7/8"-14 RH, CGA-024	9/16"-18 RH, CGA-022



FLOWMETERS

Precision flow control for MIG and TIG gas welding operations, laboratory use and many industrial applications. Use Western fittings AW-14A and AW-3 to attach flowmeters to station drops.

Note: Maximum inlet pressure 50 psig.

PART NUMBER	GAS SERVICE	RANGE
RWS-2-7	Nitrogen	0-100 scfh
RWS-2-13	Argon/Carbon Dioxide	0-70 scfh
FM601	Air	0-15 LPM



MANIFOLD REGULATORS, IN-LINE REGULATORS

MANIFOLD REGULATORS

The RM Series manifold regulator is a pressure compensated single stage design (oxygen is two-stage) and is able to maintain stable delivery pressure performance equal to a two-stage design. The unique cartridge in this regulator permits easy, single-unit replacement of vital parts in minutes. Seats, nozzle, filter, spring, seals and built-in check-relief valve can be replaced without special tools and without breaking the bonnet-to-body seal. The cartridge can be removed and a new one installed without costly down time or removing the regulator from the pipeline.

Note: Maximum inlet pressure 3000 psig (Acetylene 400 psig).



How To Order

PART NUMBER	DESCRIPTION	DELIVERY RANGE (psig)	INLET CONNECTION	OUTLET CONNECTION	REPLACEABLE CARTRIDGE NO.
RM-1-1	Acetylene	1-15	1-11 1/2" NPS EXT LH	1-11 1/2" NPS INT LH	RWC-3-59
RM-2-4	Compressed Air	20-160	1-11 1/2" NPS EXT RH	1-11 1/2" NPS INT RH	RWC-3-49
RM-4-4	Carbon Dioxide	20-160	1-11 1/2" NPS EXT RH	1-11 1/2" NPS INT RH	RWC-3-49
RM-6-4	Hydrogen	20-160	1-11 1/2" NPS EXT LH	1-11 1/2" NPS INT LH	RWC-3-49
RM-7-4	Nitrogen, Helium & Argon	20-160	1-11 1/2" NPS EXT RH	1-11 1/2" NPS INT RH	RWC-3-49
RM-8-4	Nitrous Oxide	20-160	1-11 1/2" NPS EXT RH	1-11 1/2" NPS INT RH	RWC-3-49
RDM-9-4	Oxygen	20-160	1-11 1/2" NPS EXT RH	1-11 1/2" NPS INT RH	RK-1178
RM-10-2	LPG Fuel Gases	0-45	1-11 1/2" NPS EXT LH	1-11 1/2" NPS INT LH	RWC-3-59
RS-300-MAN	Nitrogen	40-300	1-11 1/2" NPS EXT RH	1-11 1/2" NPS INT RH	RK-1020 (Repair Kit)

IN-LINE REGULATORS

Designed for installation in pipe lines where a large gas volume is required.

Note: 400 psi maximum inlet pressure.

PART NUMBER	INLET/OUTLET CONNECTION (Female)	DELIVERY PRESSURE (psig)	SCFH AIR AT 50 psig 100 psig INLET	SCFH AIR AT 100 psig 250 psig INLET	GAUGE PRESSURE RANGE
WMR-2-2	1/2" NPT	0-50	3000	3000	0-100
WMR-2-3	3/4" NPT	50-125	11,000	21000	0-200
WMR-2-4	1/2" NPT	50-125	5000	10000	0-200
WMR-2-6	3/4" NPT	100-200	6000	20000	0-400
WMR-2-8	1" NPT	100-200	6000	20000	0-400



PACKLESS DIAPHRAGM VALVES

specifications

- Diaphragm: 316L Stainless Steel
- Cv: 0.13
- Seat: PCTFE
- Working Temperature Range: -40°F to 140°F
- Body: Brass or 316L Stainless Steel
- Leakage: $<2 \times 10^{-8}$ scc/sec Helium
- Seals: Metal-to-metal with Fluoroelastomer o-ring backup
- Operating Pressure: 3,000 psig (207 bar)



PART #	DESCRIPTION
DV-4	1/4" NPT female x 1/4" NPT female-Brass

PART #	DESCRIPTION
DV-4SS	1/4" NPT female x 1/4" NPT female-Stainless Steel
DV-5SS	1/4" NPT male x 1/4" NPT female-Stainless Steel

BYPASS VALVE ASSEMBLY

Ideal for piping reserve manifold into primary gas supply line. Allows shut down of primary gas supply permitting routine maintenance and repair to be accomplished without an interruption of gas service. **Note:** Maximum pressure 600 psig.

PART NUMBER	DESCRIPTION
BVA-8	1/2" NPT Female Connections
BVA-12	3/4" NPT Female Connections



HEADER VALVES - 1/2" NPT & 3/4" NPT

High pressure CGA outlet valves for manifolding. Features controlled flow seat design with easy low torque shut-off.

1/2" NPT MALE X CGA			3/4" NPT MALE X CGA		
PART #	GAS SERVICE & CGA NUMBER		PART #	GAS SERVICE & CGA NUMBER	
WMV-2-3	Argon, Helium, Nitrogen	CGA-580	WMV-2-35	Carbon Dioxide	CGA-320
WMV-2-4	Compressed Air	CGA-346	WMV-2-36	Nitrous Oxide	CGA-326
WMV-2-7	Carbon Dioxide	CGA-320	WMV-2-37	Compressed Air	CGA-346
WMV-2-8	Oxygen	CGA-540	WMV-2-38	Hydrogen	CGA-350
WMV-2-14	Nitrous Oxide	CGA-326	WMV-2-39	Oxygen	CGA-540
WMV-2-19	Hydrogen	CGA-350	WMV-2-40	Argon, Helium, Nitrogen	CGA-580
WMV-2-30	Acetylene	CGA-510	WMV-2-43	Industrial Air	CGA-590
WMV-2-32	Industrial Air	CGA-590			



VALVES

1/4 TURN BALL VALVES

specifications

- Forged Bronze Body
- PTFE Seals
- Chrome Plated Ball
- Steel Handle (plastic coated)
- 600 psig Maximum Working Pressure
- Cleaned for Oxygen

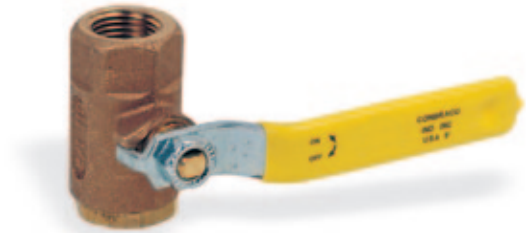

PART NUMBER	DESCRIPTION
WMV-5-11	1/4" NPT female
WMV-5-8	1/2" NPT female
WMV-5-9	3/4" NPT female

MASTER VALVES

Designed specifically for high pressure compressed gas manifold piping requirements. Large tee handle for easy operation. For use with non-corrosive gases.

PART NUMBER	DESCRIPTION
WMV-2-16	1/2" NPT female inlet & outlet
WMV-2-11	3/4" NPT female inlet & outlet



LINE STATION VALVES

Western's line station valves are designed for use with Oxygen, Acetylene, Inert gases and Liquefied Fuel Gases at station outlets of line distribution systems. The 7/8 - 14 outlets follow CGA E-1 specifications (CGA-024 RH for Oxygen and CGA-025 LH for Fuel Gases). These valve outlets and the mating regulator inlet nuts prevent the danger of possible attachment of a station regulator to a high pressure cylinder.

PART NUMBER	DESCRIPTION
WSV-1-1P	Plain valve, Oxygen & Inert Gases
WSV-1-2P	Plain valve, Fuel Gases
WSV-1-1	With gas tight cap & chain, Oxygen & Inert Gases
WSV-1-2	With gas tight cap & chain, Fuel Gases
WSV-1-1DC	With dust cap & chain, Oxygen & Inert Gases
WSV-1-2DC	With dust cap & chain, Fuel Gases



FITTINGS

UNION ADAPTORS, TAILPIECES & NUTS - WORKING PRESSURES TO 3000 psig

UNION NUTS			
Figure	Female Thread	Length	Part Number
1	1" - 11-1/2" NPS RH	1.75"	WHF-3-29
1	1" - 11-1/2" NPS LH	1.75"	WHF-3-30

UNION ADAPTORS					w/ Nickle Plated Phosphorous Bronze Filter
Figure	Outlet	Inlet	Length	Part Number	
2	1/2" NPT	1" - 11-1/2" NPS RH	2.187"	WHF-3-31	WMS-1-40
2	1/2" NPT	1" - 11-1/2" NPS LH	2.187"	WHF-3-32	WMS-1-41
2	3/4" NPT	1" - 11-1/2" NPS RH	2.230"	WHF-3-33	WMS-1-42
2	3/4" NPT	1" - 11-1/2" NPS LH	2.230"	WHF-3-34	WMS-1-43
2	3/8" NPT	1" - 11-1/2" NPS RH	3.125"	WHF-3-37	WMS-1-44
2	3/8" NPT	1" - 11-1/2" NPS LH	3.125"	WHF-3-38	WMS-1-45

TAILPIECES			
Figure	Male Thread	Length	Part Number
3	3/8" NPT	2.40"	WHF-3-36
3	1/2" NPT	2.94"	WHF-3-35

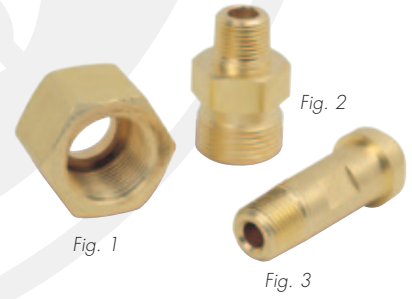

PIPELINE CHECK VALVES

Ideal for installation downstream of the manifold, designed for high flow rates and working pressures up to 3,000 psig. These brass body, female by female check valves are cleaned for use with oxygen.

PART NUMBER	INLET	OUTLET	SEAT MATERIAL
CVF-8F	1/2" NPT Female	1/2" NPT Female	EPDM
CVF-12F	3/4" NPT Female	3/4" NPT Female	Neoprene



CHECK VALVE OUTLETS - CGA X 1/2" NPT MALE

For added safety, check valve outlets are assembled in the oxygen manifold headers. Check valve outlets are safer than conventional header valves; they minimize the danger of "heat of recompression" associated with oxygen by discharging the heat. Check valves provide automatic gas shut off if a pigtail ruptures, preventing possible injury to the operator.

PART NUMBER	CGA NUMBER AND GAS SERVICE	WORKING PRESSURE
WMS-1-53	CGA-540 Oxygen, RH Male	3000 psig
WMS-1-54	CGA-580 Helium, RH Female	3000 psig
WMS-1-59	CGA-326 Nitrous Oxide, RH Male	3000 psig
WMS-1-60	"C" Size-7/8-14 RH-Inert Gases	200 psig
WMS-1-61	"C" Size-7/8-14 LH Water and Industrial Air	200 psig
WMS-1-62	CGA-346 Compressed Air, RH Male	3000 psig
WMS-1-65	CGA-320 Carbon Dioxide, RH Male	3000 psig
WMS-1-67	CGA-300 Acetylene, LH Male	500 psig
WMS-1-99	CGA-350 Hydrogne, LH Male	3000 psig
WMS-1-100	CGA-510 Acetylene, LH Female	500 psig



RELIEF VALVES - 1/4" NPT & 1/2" NPT

Ideal for cryogenic pressure vessel (vapor area), manifolds and other demanding applications. Not recommended for corrosive gases or liquid cryogenic applications. *CO₂ Models

1/4" NPT (WITH WEEP HOLE)	1/4" NPT (WITHOUT WEEP HOLE)	1/2" NPT (WITHOUT WEEP HOLE)
WMV-4-22	WRV-4-100	WMV-8-60
WMV-4-35	WRV-4-125	WMV-8-75
WMV-4-50	WRV-4-200	WMV-8-100
WMV-4-100	WRV-4-230	WMV-8-150
WMV-4-125	WRV-4-235	WMV-8-200
WMV-4-200	WRV-4-250	WMV-8-250
WMV-4-235	WRV-4-300	WMV-8C-300*
WMV-4-250	WRV-4-350	WMV-8-300
WMV-4-300	PIPE AWAY ADAPTOR: WMV-4-7	WMV-8-350
WMV-4-350		WMV-8-375
WMV-4C-350*		WMV-8-450
WMV-4-400		PIPE AWAY ADAPTOR : WMV-8-7
WMV-4C-400*		
WMV-4C-450*		



HEADER COMPONENTS

BRASS PIPE

PART NO.	LENGTH	SIZE	PART NO.	LENGTH	SIZE
*(1/2" PIPE WALL THICKNESS - .196") * (3/4" PIPE WALL THICKNESS - .230") THREADED PIPE NIPPLES					
WHF-3-1	1-1/2"	1/2" NPT	WHF-3-9	1-1/2"	3/4" NPT
WHF-3-2	2"	1/2" NPT	WHF-3-10	2"	3/4" NPT
WHF-3-3	4"	1/2" NPT	WHF-3-11	4"	3/4" NPT
WHF-3-19	6"	1/2" NPT	WHF-3-21	6"	3/4" NPT
WHF-3-5	8-1/2"	1/2" NPT	WHF-3-13	8-3/8"	3/4" NPT
WHF-3-7	11-1/2"	1/2" NPT	WHF-3-16	11-3/8"	3/4" NPT

PART NO.	LENGTH	SIZE	PART NO.	LENGTH	SIZE
CLEANED FOR OXYGEN					
WHF-3-23	2"	1/2" Nom			
WHF-3-4	4"	1/2" Nom			
WHF-3-20	6"	1/2" Nom			
WHF-3-6	8-1/2"	1/2" Nom			
NOT CLEANED FOR OXYGEN					
WHF-3-120	6'	1/2" Nom	WHF-3-122	6'	3/4" Nom
WHF-3-17	12'	1/2" Nom	WHF-3-18	12'	3/4" Nom

Note: 12 Foot Lengths Must Ship Via Common Carrier

MANIFOLD PIPE & PIPE FITTINGS, BRASS
BRASS ALLOY 360,
Pressures to 3000 psig (20,700 kPa)



PIPE NIPPLE LENGTH

NOMINAL PIPE LENGTHS
BRASS ALLOY 360,
PRESSURES TO 3000 psig (20,700 kPa)



SHORT PIPE LENGTH

PIPE TEES - FEMALE

PART NO.	REF A	REF B	REF C	REF E	TEES
*(1/2" PIPE WALL THICKNESS-.196") * (3/4" PIPE WALL THICKNESS-.230") THREADED PIPE NIPPLES					
WHF-4-7	1/2" NPT	1/2" NPT	1/2" NPT	2-1/2"	FIGURE 1
WHF-4-10	3/4" NPT	3/4" NPT	3/4" NPT	2-3/4"	FIGURE 1
WHF-4-14	.843"-.847"	.843"-.847"	1/2" NPT	2-1/2"	FIGURE 2
WHF-4-18	1.053"-1.057"	1.053"-1.057"	3/4" NPT	2-3/4"	FIGURE 2
WHF-4-13	1/2" NPT	1/2" NPT	.843"-.847"	2-1/2"	FIGURE 3
WHF-4-21	.843"-.847"	1/2" NPT	1/2" NPT	2-3/4"	FIGURE 4
WHF-4-22	1.053"-1.057"	3/4" NPT	3/4" NPT	2-1/2"	FIGURE 4
WHF-4-1	1.053"-1.057"	1.053"-1.057"	1.053"-1.057"	2-3/4"	FIGURE 5
.843"-.847" = 1/2" Pipe Slip * 1.053"-1.057" = 3/4" Pipe Slip					

PIPE TEES, FEMALE

PRESSURES TO 3000 psig (20,700 KPA)



FIGURE 1

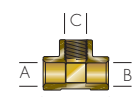

FIGURE 2 (SLIP THROUGH)

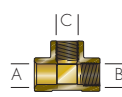

FIGURE 3



FIGURE 4

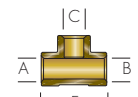
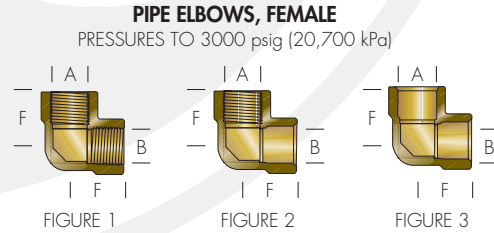

FIGURE 5 (SLIP THROUGH)

HEADER COMPONENTS, CAPS & PLUGS

PIPE ELBOWS – FEMALE

PART NO.	REF A	REF B	REF F	ELBOWS
WHF-4-8	1/2" NPT	1/2" NPT	1 1/4"	FIGURE 1
WHF-4-11	3/4" NPT	3/4" NPT	1 3/8"	FIGURE 1
WHF-4-15	1/2" NPT	.843"-.847"	1 1/4"	FIGURE 2
WHF-4-19	3/4" NPT	1.053"-1.057"	1 3/8"	FIGURE 2
WHF-4-2	.843"-.847"	.843"-.847"	1 1/4"	FIGURE 3
.843" – .847" = 1/2" Pipe Slip* 1.053"-1.057" = 3/4" Pipe Slip				



PIPE CROSSES – FEMALE

PART NO.	REF A	REF B	REF C & D	REF E	CROSSES
WHF-4-9	1/2" NPT	1/2" NPT	1/2" NPT	2-1/2"	FIGURE 1
WHF-4-12	3/4" NPT	3/4" NPT	3/4" NPT	2-3/4"	FIGURE 1
WHF-4-16	.843"-.847"	.843"-.847"	1/2" NPT	2-1/2"	FIGURE 2
WHF-4-23	.843"-.847"	1/2" NPT	1/2" NPT	2-1/2"	FIGURE 3
.843" – .847" = 1/2" Pipe Slip					

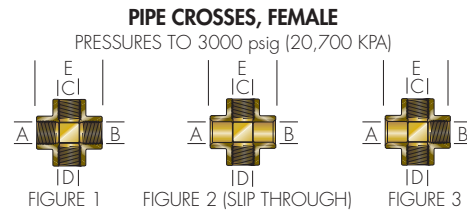

PIPE THREAD CAPS & PLUGS

PART NO.	DESCRIPTION	MATERIAL	HEX
PRESSURES TO 3000 psig (20,700 kPa)			
PC-2HP	Cap, 1/8" NPT F	Brass	5/8"
PC-4HP	Cap, 1/4" NPT F	Brass	3/4"
PC-6HP	Cap, 3/8" NPT F	Brass	7/8"
PC-8HP	Cap, 1/2" NPT F	Brass	1-1/8"
P-4HP	Hex Plug, 1/4" NPT M	Brass	5/8"
P-6HP	Hex Plug, 3/8" NPT M	Brass	7/8"
P-8HP	Hex Plug, 1/2" NPT M	Brass	1-1/8"
PRESSURES TO 6000 psig (41,300 kPa)			
P-4SS	Hex Plug, 1/4" NPT	Stainless Steel	5/8"

PIPE THREAD CAPS & PLUGS



PURGE ASSEMBLIES

Contamination cannot be tolerated in a high purity system. During cylinder change-out, oxygen and moisture from the atmosphere enter the manifold or regulator and become trapped. If allowed to remain, these impurities are swept into the system. Depending upon the flow rate, these impurities can disrupt the process for days or even weeks.

Designed for use with regulators and manifolds to allow purging of the system between cylinder change-outs. Each unit includes a check valve and shut-off valve to minimize possible back flow of cylinder gas into the purge source. Assembly instructions are included for PT and PC models. PS models are shipped pre-assembled.

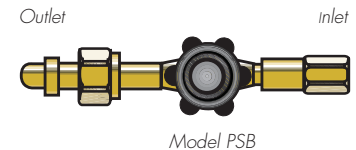
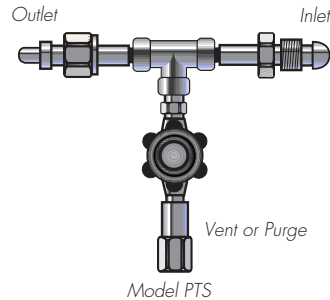
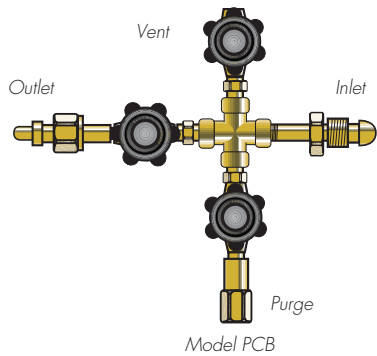

HOW TO ORDER

MODEL #	ASSEMBLY MATERIAL (U)	CHECK VALVE SEAT MATERIAL (V)	INLET CONNECTION (W)	OUTLET CONNECTION (X)	PURGE CONNECTION (Y)	VENT CONNECTION (Z)
PS – Straight Purge	S - 316 L Stainless Steel	V - Fluoroelastomer (for most gases)	(1) 1/4" NPT Female (2) 1/4" NPT Male (3) 1/4" Compression		N/A	N/A
PT – Tee Purge	B - Brass	E - EPDM (for use w/N ₂ O & CO ₂)	(4) To connect to HSAD & HSMS (old style) (5) CGA-580 Valve Outlet (6) CGA-580 Nut & Nipple (7) CGA-346 Valve Outlet (8) CGA-346 Nut & Nipple (9) CGA-350 Valve Outlet (10) CGA-350 Nut & Nipple (11) CGA-320 Valve Outlet (12) CGA-320 Nut & Nipple (13) CGA-326 Valve Outlet (14) CGA-326 Nut & Nipple (15) CGA-510 Valve Outlet (16) CGA-510 Nut & Nipple (17) CGA-540 Valve Outlet (Brass Only) (18) CGA-540 Nut & Nipple (Brass Only) (19) CGA-590 Valve Outlet (20) CGA-590 Nut & Nipple			N/A
PC – Cross Purge						

Western Innovator Manifold Header Configurations

Standard



10" on Centers
(13" for Acetylene & LPG)

Staggered



5" on Centers
(6.5" for Acetylene & LPG)

Vertical Crossover



10" on Centers
(13" for Acetylene & LPG)

Crossover Floor Stand Required



10" on Centers
(13" for Acetylene & LPG)

Note: Custom L-Shaped and U-Shaped also available, customer supplied dimensional drawing required.

This catalog provides a comprehensive source of information on Western's line of products used in the control, transmission and storage of compressed gases for industrial and other related applications. Product descriptions include information on available gas services, sizes, operating pressures, applications and optional features, as appropriate. Additional information is available through Western's customer service department at 1-800-783-7890.

Western adheres to the necessary organizational mandates and regulatory bodies to ensure safe quality products are delivered to the consumer. Where applicable, all products meet the Compressed Gas Association (CGA) guidelines.

In conjunction with other applications, Western products can co-mingle with the requirements of various related agencies (as listed below).

Western manufactures products under the stringent controls to assure that safe products are delivered to the marketplace. Users of Western products must adhere to the instructions provided with certain products. For more information on the safe handling and proper installation of compressed gas equipment, contact the following agencies or Western's customer service department.

Compressed Gas Association 14501 George Carter Way Suite 103 Chantilly, VA 20151 703-788-2700 www.cganet.com	Food & Drug Administration 5600 Fishers Lane Rockville, MD 20857 1-800-INFOFDA www.fda.gov	National Fire Protection Association One Batterymarch Park Quincy, MA 02269 617-770-3000 www.nfpa.org	OSHA Occupational Safety & Health Administration 200 Constitutional Ave. Washington, DC 20210 www.osha.gov	Underwriter Laboratories Incorporated 333 Pfingsten Road Northbrook, IL 60062-2096 1-877-UL HELPS www.ul.com
--	--	--	---	---

For more information on Western's other product portfolios, contact Customer Service at 1-800-783-7890.

- MEDICAL EQUIPMENT PORTFOLIO** Medical regulators, portable oxygen systems, flowmeters, fittings and transfill systems, homecare products, emergency oxygen units
- INDUSTRIAL EQUIPMENT PORTFOLIO** Regulators, flowmeters, cylinder adaptors, CGA fittings, flash arrestors, hotspotters, hose repair kits, valves, pigtails
- INFLATION EQUIPMENT PORTFOLIO** High quality helium equipment including inflators, filling stations, cylinders, manifolds, accessories and replacement parts

For 60 years, Western has been supplying innovative solutions in gas management systems to the industrial, medical and helium gas markets.





ISO 9001/ISO 13485 Registered Quality System

Western/Scott Fetzer Co.
875 Bassett Road
Westlake, Ohio 44145 - 1142
440.871.2160
Fax: 440.835.8283
800.783.7890
www.westernenterprises.com
B20614 ECN-16056 (1302)