



Electric Actuators



COMPACT[®]
AUTOMATION PRODUCTS



Custom Application Solutions are Our Specialty



Compact Automation offers durable, reliable and innovative industrial solutions with high value and low life-cycle cost to customers around the globe in diversified industrial end markets.

With our extensive engineering capability and 96 patents globally with a combined 1,290 years of experience in over 120 product lines, comprised of 82,000 standard and 47,000 custom products ranging from custom automation to lift and turn cylinders, we can make your application a success no matter what the engineering challenge.

Life Sciences

Compact Automation is a market-leading manufacturer of motion control and precision automation products that supplies customized cylinder solutions to the medical, pharmaceutical and life sciences industries.

Electronics

We provide electronics manufacturers with specialized solutions in automation and motion-control through diversified products.

Packaging

Compact Automation is a premier supplier of engineered solutions for multi-motion and custom automation products for packaging applications worldwide.

Food and Beverage

We design and manufacture products that provide solutions to the food and beverage industry where clean and sterile conditions must be maintained for food safety, while providing optimal performance and value to the customer.

Automation

We offer a wide array of customized products that meet today's highest quality standards in the most demanding manufacturing environments.

Oil and Gas

Consider us your single source for highly engineered application solutions for offshore and sub-sea precision motion control applications.

Compact Automation is Who We Are

Compact Automation was started in 1974 in Cleveland, Ohio by an engineer who frequently needed a small and easy to mount air cylinder and had an idea of how to design one. The result was the world's first space-efficient air cylinder product line. While most competitors now have a similar product offering, Compact is still the leader, offering industry best force-to-size ratios, the most available standard options, and the ability to customize.

In 2004, Turn-Act rotary actuators were added to the Compact Automation product offering. Like Compact, Turn-Act rotary actuators have industry leading torque-to-size ratios and product configurability. Together they form a powerful product offering.

Today Compact is located in Westminster, SC and is part of ITT, a global manufacturer of highly engineered products. Compact Automation is a leading supplier of high-value actuator solutions to original equipment manufacturers in many industries. Our knowledge and experience enable us to provide unique solutions to our customers most difficult challenges. Don't design your equipment around an actuator, design your equipment the way you want it and we will design an actuator to fit.

**Delivering
Enduring
Solutions to
Global
Industries.**

NIASA at a Glance

NIASA was started in 1984 as a result of the expansion of the German group NEFF. For more than 30 years, NIASA has designed and manufactured high quality linear actuators that are used in the automation of industrial machinery. This rich experience allows NIASA to provide the right solution for each application. Much like Compact Automation, NIASA's technical customer service team works hand-in-hand with it's R&D department to establish an in depth understanding of the customer's requirements to design the right product.

NIASA is located in the town of Lasarte-Oria in the industrial region of northern Spain. Today their 65,000 square foot manufacturing facility produces more than 100 electric actuators per day. NIASA holds ISO 9001: 2008 and ISO 14001: 2004 certifications for their quality and environmental management systems.

NIASA has a global distribution network. In the United States and Canada, their products are exclusively available through Compact Automation Products.

Full product catalogs are available for download at NIASA's website located at: www.niasa.es

Screw Jacks



NIASA adapts
to customer's
requirements

NIASA N/W/R Series Screw Jacks are a combination of a screw with a gearbox. There are three types of configurations that can be adapted to different requirements:

N: The screw moves when the gearbox input shaft (worm shaft end) is activated. It includes a rounded screw protection tube on the back.

W: The screw engages, as in configuration N but with the difference that the back protective tube is square section, which means it can be an anti-rotating screw.

R: The screw does not move with the driving of the worm shaft, it only turns; it is the corresponding nut that moves along the screw. In applications that so require, there is a possibility to protect the screw with a bellow (available in different materials), to protect it in the outside environment and make the screw jacks suitable for outdoor operations or environments with a certain atmospheric aggressiveness.

Screw jacks are often the most optimal technical and economical solution for applications that require linear, precise and safe movement, for transfer and for elevation, mainly for medium-heavy loads and medium-low speeds.

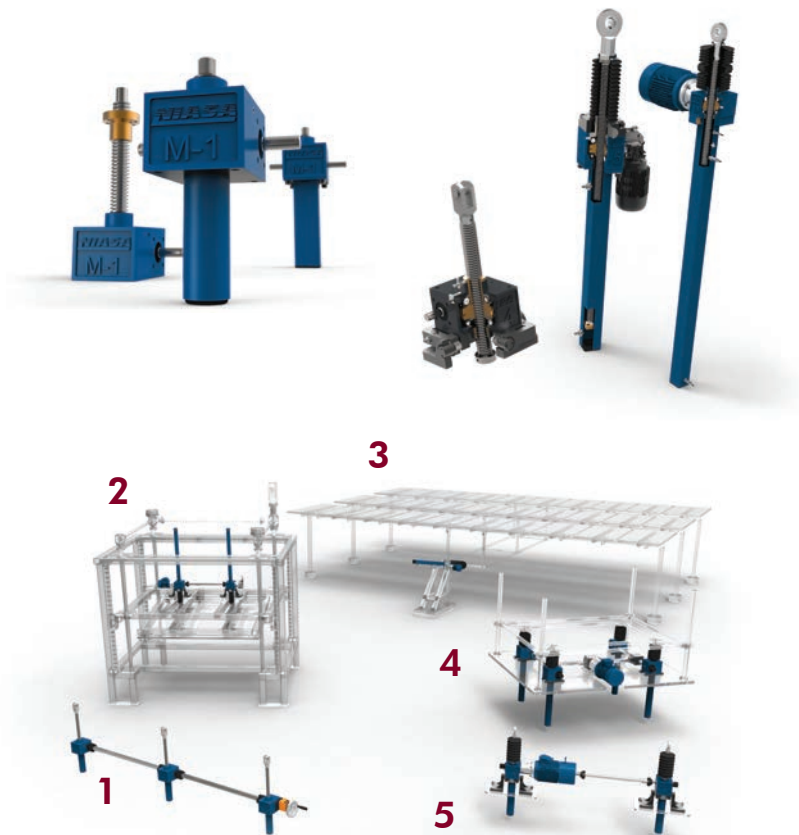

1 Manual Positioning System

2 Machine Tilting System

3 Photovoltaic Installation

4 Platform Elevation System

5 Tilting Elevation System

NIASA designs
for its customers

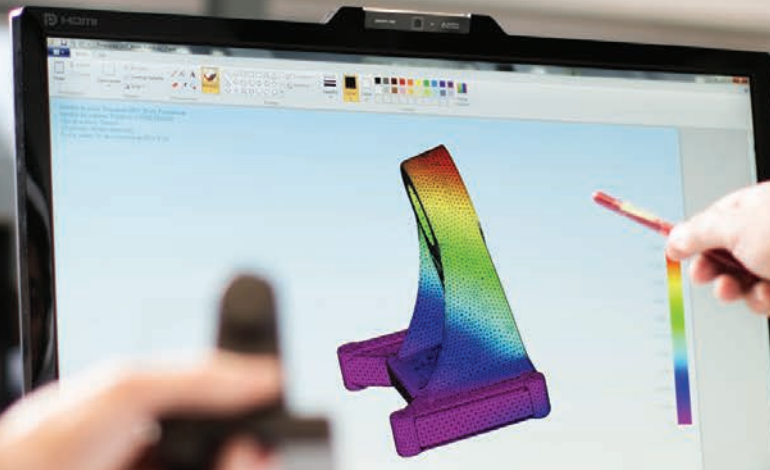

NIASA F/A Series Linear Actuators are electro-mechanical cylinders in which a round stem moves inside a second tube, of either steel or aluminum. The movement of the stem is achieved with the combination of an interior nut which is attached to it, and an electrical motor that drives the screw/nut. The power transmission from the motor may be direct or by means of different gear solutions and toothed belts.

Against solutions with exposed screws, protecting them with an external stem means that the equipment is highly sealed and can operate in the most aggressive conditions, with the presence of dust or liquid. The stem provides an extraordinary capacity for buckle load against axial compression loads.

These types of actuators are the best solution in practically any application that requires precise and safe linear movement, whether it is for transfer or for elevation, regardless of the speed required. Their main advantages against pneumatic or hydraulic systems are:

- Greater movement and positioning precision
- Superior energy efficiency, through high performance
- Easier and faster assembly, since no hydraulic or pneumatic power sources are required, just an electric motor mounted on the unit itself.

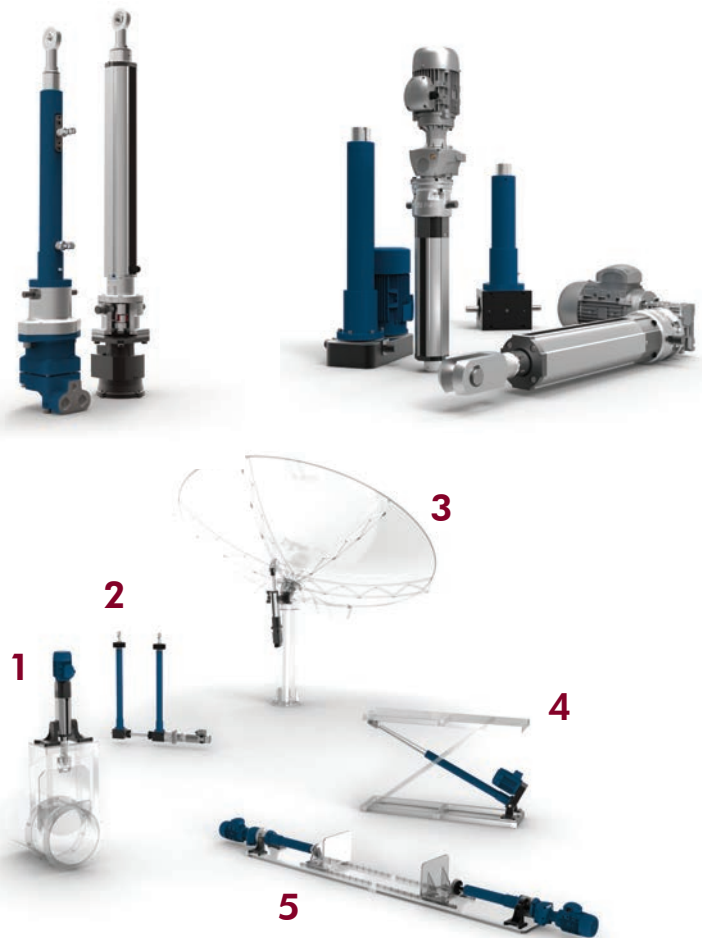

- | | |
|------------------------------|---------------------------|
| 1 Shutter System | 4 Scissor Lift |
| 2 Vertical Drive System | 5 Horizontal Drive System |
| 3 Antenna Orientation System | |



**NIASA specializes
in linear movements**

NIASA FM/AM Series Electro-mechanical Actuators combine the sleeve and stem system of the F/A Series linear actuators with the gearbox of the screw jacks, thus obtaining the most advantageous features of both types of product. This way, the FM/AM Series electro-mechanical actuators become the optimal technical solution for applications that require the movement specifications of a screwjack, with the additional advantage of being able to work under the most demanding environmental conditions. These actuators also offer an extensive range of:

- Axial load capacities, from 5 up to 250kN
- Advance speeds; depending on the screw pitch and the gearbox, two possible reductions are available depending on the size of the actuator, from 4:1 to 40:1
- Fastening accessories for optimal adaptation to the most varied systems.

NIASA FHM/AHM Series Actuators have evolved from the FM/AM Series, aimed at specific requirements in the solar energy generation sector (photovoltaic, thermosolar, etc.). They can also be used in any other kind of application with demanding environmental conditions. The gearbox is round and not cubic, and the input shaft offers the possibility to connect directly to any type of drive. Additionally, the "D" variant includes a second reduction, thus avoiding the use of reducers in solar tracking or similar applications, where very slow advance speeds are required.

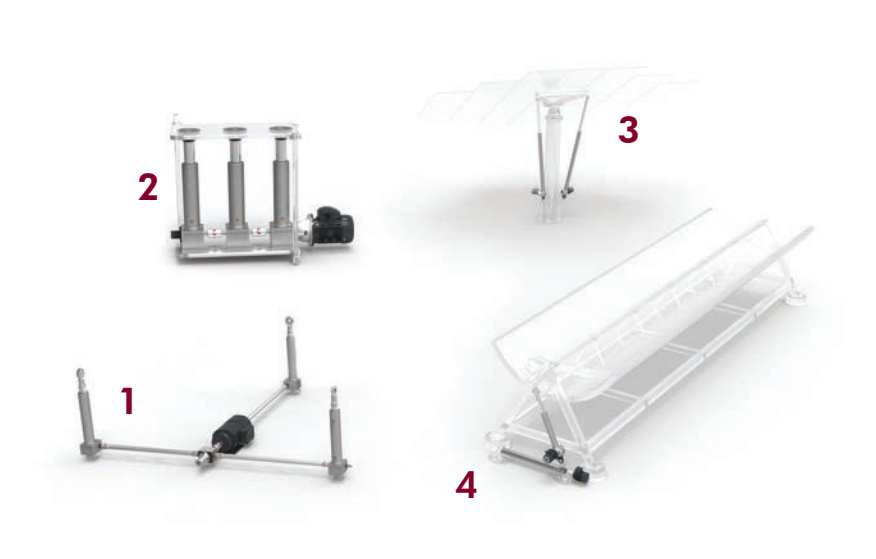

1 Three Shaft Screw Jack System	3 Solar Heliostat Tracker 2 Shafts
2 Three Shaft Actuators System	4 Cylinder/Parabolic Solar Concentration

NIASA believes in the value of ideas

NIASA bevel gearboxes transfer energy through conical gears, with spiral teeth in optimized geometry. They are manufactured from tempered steel, cut according to Klingelnberg/Gleason standards and overlapped. One of the gears is mounted on a dual-supported bushing, while the other gear is overhanging. The standard play between the sides of the teeth is less than 10 angular minutes, and may be less than 6 at the customer's request.

The box, with a compact and highly rigid design, is made with modular iron and spherical graphite casting and is machined on the six sides. The bevel gearboxes are supplied with ball bearings (standard) or conical roller bearings (at customer's request), sealed and lubricated, depending on the load, speed, sonority, temperature, etc. It is lubricated with high-performance synthetic oil with the possibility for NSF-H1 approval for the food industry.

The efficiency of the bevel gearboxes, depending on the torque transferred, the lubrication and the assembly position, is usually higher than 98%. Ventilation is necessary for working temperatures over 50°C. Optional aeration and venting filters with integrated grease separators are mounted on the sides of the gearbox with tube elbows.

The sealing of each box is guaranteed by means of O-rings, caps. Radial shaft seals made from NBR, Vitón or PTFE, are available with or without a dust protection lip.

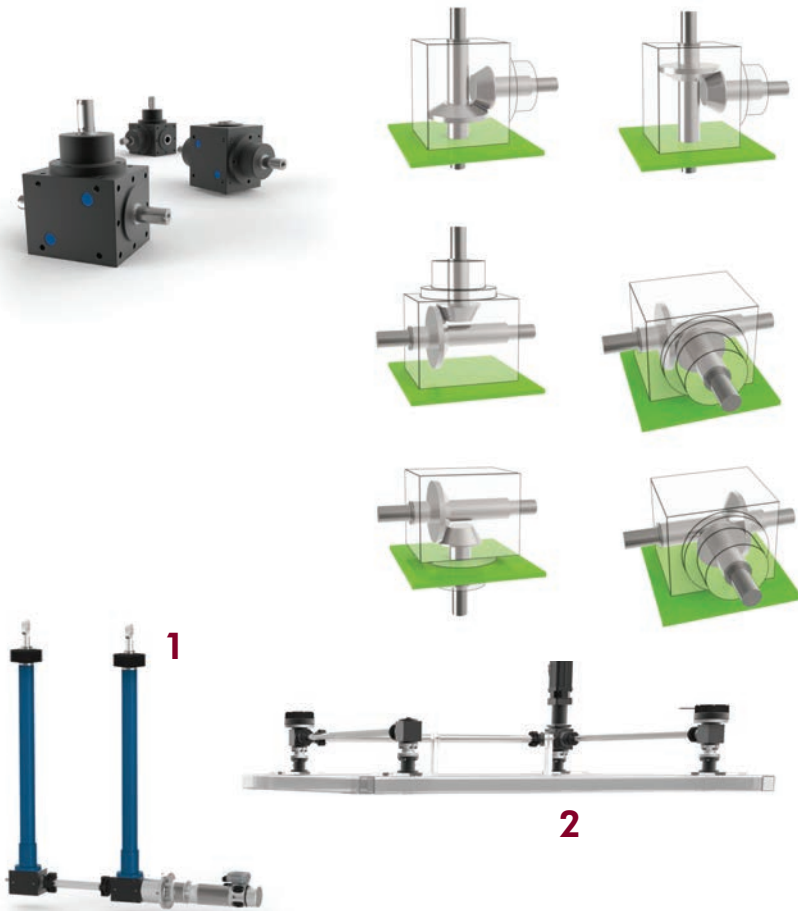

1 Vertical Positioning System

2 Four Shaft Transmission System

Rodless Mechanical Cylinders

NIASA works for
its customer success



NIASA CMH rodless mechanical cylinders can form part of almost any type of machinery, as long as it exercises linear forces or moves one or more axes in a controlled manner. They are used separately, or combined with each other, given the multiple possibilities of combination offered. Basically, they are mechanical elements that convert rotating entry movements into linear exit movements. They are characterized because their carriage (the element that exercises the force on the machine) is actioned by a nut, which in turn is pushed by a screw that turns.

Each carriage is fitted with either a single ballscrew nut (M), or a trapezoidal nut (TR) depending on desired speed, precision, work cycle, etc., and are supported by bearings on their ends. The carriages are mounted on a prismatic linear bearing rail that is fitted inside an extruded aluminum body. The set is protected from the exterior by the profile itself.

Conceptually the difference compared with CMH type rodless mechanical cylinders is that the NIASA CMK is distinguished because the carriage is mounted on a linear bearing that is driven via a steel braided toothed belt.

This type of transfer enables linear speeds of up to 5 m/s to be reached, which is comparable to those offered by pneumatic cylinders, although with the advantage of being able to carry out an almost infinite number of intermediate stops on the run, with total control of speed and positioning.

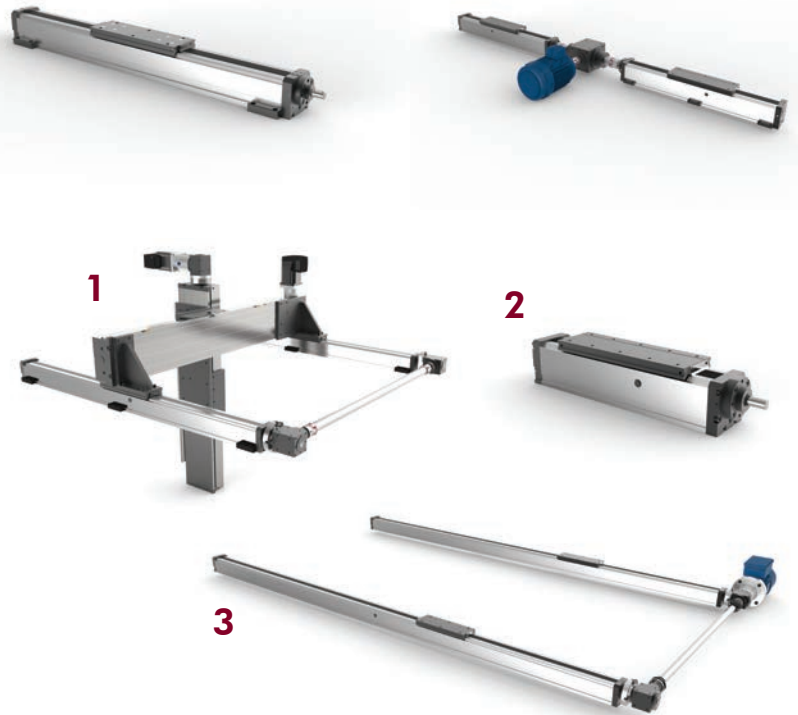

1 Three Axis System

3 Two Arm Feeder

2 Compact Linear Unit



Screws transform a rotation movement into a linear movement and vice versa; the latter depends on the type of screw and its dimensions.

NIASA offers an extensive range of screws for all types of applications, within sectors as varied as machine tools, aeronautics, transport and handling industry, renewable energies, etc.

NIASA quality standards guarantee the highest levels of reliability on the entire range of screws and nuts.

NIASA supplies trapezoidal as well as ball screws. The benefits of ball screws over trapezoidal screws are the following:

- Greater positioning precision
- Longer useful life
- Greater efficiency
- Working at higher speeds
- Lower heat generation
- No slipping or gripping effects

Trapezoidal screws are usually the most economical and their features suit numerous application requirements.



1 Trapezoidal, Balls, and Security Nuts

3 Ball Screw and Nut

2 Trapezoidal Screw

4 Pre-loaded Nuts

Linear Tables



NIASA is right beside its customers

NIASA linear tables are translating units, applicable to practically any precise positioning problem. In combination with a rotary device a fourth axis for radial positioning can be provided.

They can be combined manually in their simplest version, or by CNC, and can move small loads and large loads, always with reduced energy consumption.

The linear tables are light, modular and easy-to-assemble units, either separately or combined with each other. They can be assembled on one, two or three axes, thereby achieving the optimal solution for an infinity of applications.

They are equipped with high precision recirculating ball guideways allowing smooth and low noise operation.

They also incorporate high precision laminated or rectified ball screws (depending on the positioning tolerance); and there is also the possibility of installing pre-loaded double nuts, in order to eliminate, or reduce the backlash between the nut and screw.

They can also be supplied with trapezoidal screws for low speed and low precision applications.

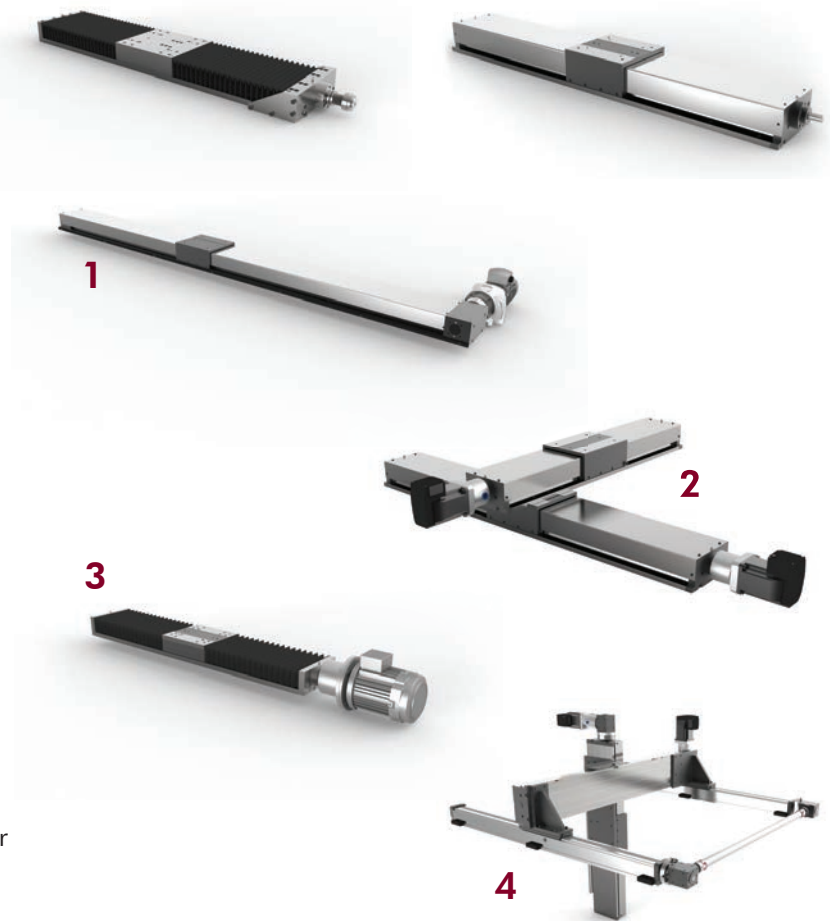

1 Standard Linear Table

3 Covered Linear Table

2 Two Axis System

4 Four Axis System

Compact Automation Products, LLC
105 Commerce Way
Westminster, SC 29693
Tel: 864.647.9521
Fax: 864.647.9574
www.compactautomation.com