



## Two-Hand, No-Tie-Down (THNTD) Circuit



**Size:** 6.25" x 3.50" x 3.25"

**Temperature:** 32 to 140°F

**Pressure Range:** 50 to 120 psig

**Use:** The main function of this control is to require a machine operator to use both hands at the same time to actuate the equipment, helping to insure that the operator's hands are not in a position to be injured by the machine as it is in motion.

**Operation:** Clippard's Minimatic® VA-023 circuit module is a self-contained modular circuit board with all interconnections required to provide a Two-Hand, No-Tie-Down (THNTD) pneumatic circuit. Use of the VA-023 will assure simple and rapid installation of your Two-Hand, No-Tie-Down circuit.

Part No.	Description
<a href="#">VA-023</a>	THNTD Circuit without Palm Buttons
<a href="#">VA-023-GN</a>	THNTD Circuit with Green Palm Buttons
<a href="#">VA-023-RD</a>	THNTD Circuit with Red Palm Buttons

### Bill of Materials in Assembly

Qty.	Part No.	Description
1	<a href="#">R-315</a>	3-Way Modular Multi-Piloted Valve
2	<a href="#">R-401</a>	4-Way Modular Valve
1	<a href="#">CM-023-PQ</a>	THNTD Circuit Manifold
2*	<a href="#">PB-1-GN</a>	Green Palm Button with (2) 1/4" Push-Quick Fittings
2*	<a href="#">PB-1-RD</a>	Red Palm Button with (2) 1/4" Push-Quick Fittings
10'*	<a href="#">URT1-0805-GNT</a>	1/4" O.D. Polyurethane Tubing, Green
4"	<a href="#">URT1-0503-YLT</a>	5/32" O.D. Polyurethane Tubing, Yellow
4*	<a href="#">PQ-UE08P</a>	1/4" Universal Elbow Push-Quick Fitting
1	<a href="#">PQ-PG05</a>	5/32" Push-Quick Plug

\* Comes with "-GN" and/or "-RD" options only

All components are also available for purchase

The [CM-023](#) subplate is available with 1/8" NPT ports on A, B, C & D, and #10-32 threads for Ports E & F

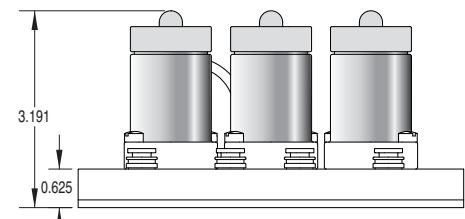
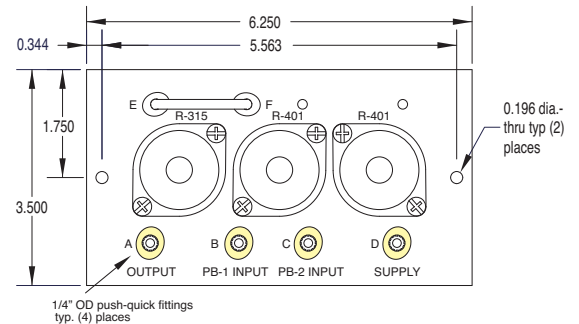

(2) Green Palm Buttons (PB-1-GN) are included with Part No. [VA-023-GN](#)

(2) Red Palm Buttons (PB-1-RD) are included with Part No. [VA-023-RD](#)

[View additional information and useful videos](#)



### Limited Warranty

When properly used, this equipment meets ANSI B11.1-1971 and OSHA 1910.217 safety standards for Two-Hand, No-Tie-Down controls. It is the buyer's sole responsibility to determine proper application, location installation, use and maintenance of this equipment. This equipment performs the function of a Two-Hand, No-Tie-Down control only. All other prescribed safety devices must be used with this equipment. Seller shall not be responsible for any failure to so comply which results from the application, installation, location, operation, use or maintenance of this equipment or from alteration of the equipment by persons other than the seller, or from design or instruction furnished by the buyer or his agents. Seller's liability shall be limited to replacement or modification of the equipment to comply with OSHA standards or to refund the purchase price. Seller will be responsible for any fines, penalties or consequential damage. Clippard makes no other warranty of any kind, expressed or implied.

## VA-023 & CM-023 Special Features



**Maintained Output** occurs as long as both palm buttons are held. Release of either button terminates the output (shipped in this configuration).

**How:** Connect E to F using a piece of 5/32" O.D. tubing as a jumper



**Momentary Output** gives a single output pulse that is about 50 ms in duration.

**How:** Plug E with 5/32" Push-Quick Plug (11755 screw plug if using CM-023); F is open

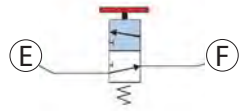

**Cancelable Output** terminates the output after a Normally-Open 3-way limit valve has been tripped, even if both palm buttons are held.

**How:** Interpose Normally-Open 3-way valve or other circuit function

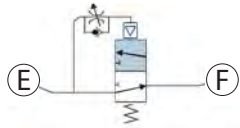

**Cancel Output after Time Delay** is a variation of Cancelable Output (above) where pneumatic delay valve, such as Clippard's Model R-331, is set to cancel the output after a designated time interval has elapsed regardless of how long the buttons are held.

**How:** Interpose Normally-Open 3-way delay valve (see R-331)



*It is the user's responsibility to determine which special feature can be safely used in their particular application. Because of the variety of applications for this equipment, detailed instructions cannot be given for each possible use. Users are warned that improper application, use, installation, maintenance and/or alterations to this product may result in malfunctions and possible damage or injuries. This device, and all equipment and/or machinery associated with it, should be tested weekly by qualified personnel for proper function and operation.*

## Two-Hand, No-Tie-Down ANSI Circuit

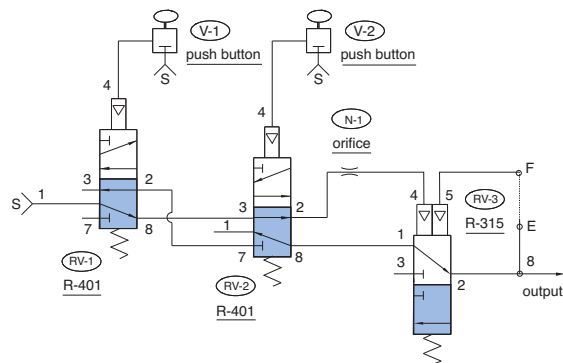

*Absolutely no alterations or modifications should be made to this circuit or its components parts.*

### Circuit Operation:

RV-3 is held open by supply air that passes through RV-1, RV-2 and N-1. When RV-1 is actuated alone, the pilot air for RV-3 flows back through the N-1 and RV-2 to atmosphere at RV-1, and RV-3 is closed by the spring. When RV-2 is actuated alone, the same sequence occurs except the pilot air from RV-3 exhausts to atmosphere via RV-2.

Restriction N-1 determines the time span during which both signals must be received in order to obtain the output. When RV-1 and RV-2 are actuated together, supply air is directed through RV-1, RV-2 and RV-3 to the output, providing a momentary output signal that is determined by N-1. If a maintained signal is required, a jumper between E and F maintains an output as long as the operator is depressing both palm buttons.

The indicator on RV-3 (R-315) must be down for an output to be obtained. If either RV-1 or RV-2 is actuated separately, their respective indicator will go up, but after approximately one second, the indicator on RV-3 (R-315) will go down showing that the valve has shifted and an output cannot be obtained. Circuit performance and sequence should be periodically observed to verify proper function.