

Clippard Push-Quick Fittings provide a simple method of connecting pneumatic components to each other and system piping. They are designed for use with both flexible hose and stiff tubing made of nylon, urethane, polyethylene or polypropylene.

Pressure Range: 0 - 150 psig @ 130°F

Vacuum: 0 to 29.5" Hg

Temperature Range: 32 to 140°F

Media: Air, Non-corrosive water

Tube Pull Out Force: >20 lb. @ 75°F (non-pressurized)

Burst Pressure: 350 psig @ 75°F

Materials: Body - Plastic Resin
Metal Stud - Nickel Plated Brass
Gripper Ring - Stainless Steel
Seals - Nitrile

Push-Quick Fittings generally provide higher flows than barbed fittings. The Push-Quick fitting allows full flow through the hose/tubing I.D. with no smaller orifice required as in barb fittings. The chart shows the comparison between barb and push in fittings for various tubing/hose sizes. Push-Quick Fittings are available in nine sizes for 1/8", 5/32", 6 mm, 1/4" and 3/8" O.D. tubing. The 5/32" fittings may also be used with 4 mm O.D. tubing.

Installation of Tubing into fitting

1. Slowly push a clean and perpendicularly cut tubing into the fitting until it comes to a dead stop.
2. Pull the tubing back gently until the Gripper Ring of the fitting grips onto the tubing and has a good seal.

Removal of Tubing from fitting

1. Push in evenly on the two long oval sides of the Release Button.
2. Pull out the tubing while keeping the Release Button depressed.
3. To reuse the tubing; cut off the lodged portion of the previously used tubing evenly and perpendicularly.

Installation of Pipe Fittings with Pre-Applied sealant

1. Tighten fitting by hand, then turn it 2 or 3 turns with a wrench until it reaches the desired torque listed.
2. If the fitting is used and the sealant coating is not in good condition, apply Teflon® sealant tape to the threads.



* 6 mm size fittings have a green release button

Barb vs Push-Quick Fittings
Flow Comparison @ 100 psig

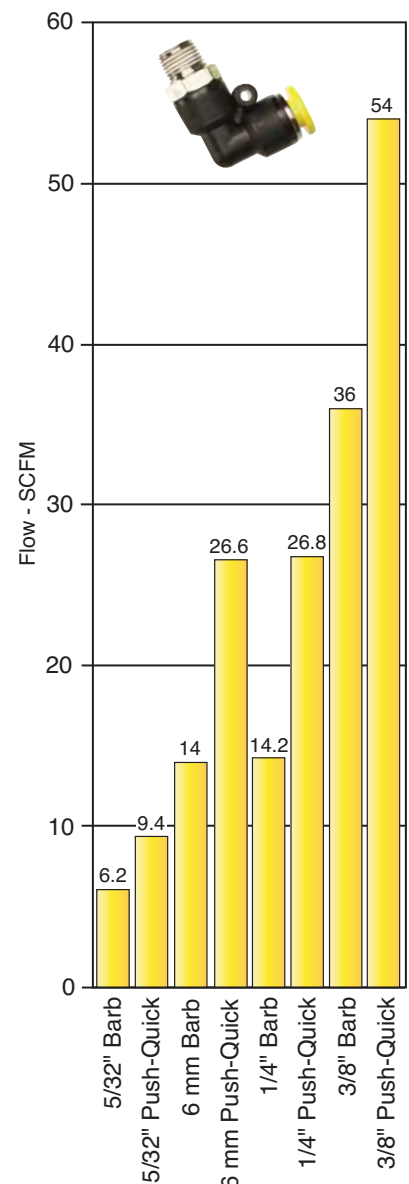

Thread Size	#10-32	1/8" NPT, R1/8	1/4" NPT, R1/4	3/8" NPT	1/2" NPT
Torque lb. - ft.	1.0 - 1.5	5.0 - 6.5	8.5 - 10.0	16.0 - 17.5	20 - 21.5

Tubing Material	Polyurethane	Polyethylene	Polypropylene	Nylon
Specified Size	+/- 0.005"	+/- 0.004"	+/- 0.004"	+/- 0.004"
Hardness (Durometer)	Shore A85 or higher	Shore D 44 or higher	Shore D 44 or higher	Shore D 44

see pages 322 through 327 for hose and tubing



PUSH-QUICK FITTINGS



Fitting Type		Tubing Size (O.D.)		Thread Size
BC - Bulkhead Connector	MA - Male Angle Connector	RU - Reduced Union	04 - 1/8" (0.125")	N - #10-32
BT - Branch Tee	MC - Male Connector	SC - Stem Coupler	04M - 4 mm (0.157")	5 - M5 Thd.
BU - Bulkhead Union	ME - Male Elbow	SE - Stack Elbow	05 - 5/32" (0.156")	6 - M6 Thd.
CC - Compact Male Conn.	MM - Male Manifold	SU - Straight Union	06M - 6 mm (0.236")	P - 1/8" NPT
CU - Cross Union	MU - Manifold Union	TU - Tee Union	08 - 1/4" (0.250")	R - R1/8
EE - Extended Elbow	PE - Plug-In Elbow	TR - Tube Reducer	08M - 8 mm (0.313")	Q - 1/4" NPT
ER - Elbow Reducer	PG - Plug	UE - Universal Elbow	10 - 5/16" (0.313")	2 - R1/4
EU - Elbow Union	RB - Reduced Branch	YC - Y Connector	12 - 3/8" (0.375")	W - 3/8" NPT
FC - Female Connector	RT - Run Tee	YU - Y Union	16 - 1/2" (0.500")	3 - R3/8
FE - Female Elbow				Z - 1/2" NPT

Threaded Fittings



Female Connector
Page 306



Male Compact Connector
Page 306



Male Connector
Page 306



Bulkhead Connector
Page 310



Male Angle Connector
Page 309



Y Connector
Page 308



Female Elbow
Page 308



Male Elbow
Page 307



Extended Elbow
Page 308



Universal Elbow
Page 308



Stack Elbow
Page 309



Run Tee
Page 307



Branch Tee
Page 307



Manifold Mount
Page 309

Non-Threaded Fittings



Straight Union
Page 310



Reduced Union
Page 311



Elbow Union
Page 310



Tee Union
Page 310



Y Union
Page 311



Cross Union
Page 310



Manifold Union
Page 310



Bulkhead Union
Page 310



Reduced Branch
Page 311



Elbow Reducer
Page 311



Tube Reducer
Page 311



Plug-In Elbow
Page 311



Tee Reducer
Page 311



Stem Reducer
Page 312



Stem Coupler
Page 312

Female Connector

(10/pack)

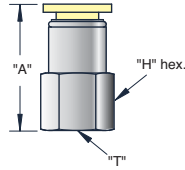

Tubing	Thread "T"	Part No.	"A"	"H" Hex.
5/32"	#10-32	PQ-FC05N	0.905"	7/16"
	1/8" NPT	PQ-FC05P	1.080"	9/16"
4 mm*	M5 x 0.8	PQ-FC04M5	0.905"	12 mm
	R1/8	PQ-FC04MR	1.080"	
6 mm*	R1/8	PQ-FC06MR	1.080"	14 mm
	R1/4	PQ-FC06M2	1.100"	17 mm
1/4"	1/8" NPT	PQ-FC08P	1.080"	9/16"
	1/4" NPT	PQ-FC08Q	1.220"	11/16"
5/16"	1/8" NPT	PQ-FC10P	1.170"	11/16"
	1/4" NPT	PQ-FC10Q	1.250"	11/16"
	3/8" NPT	PQ-FC10W	1.260"	7/8"
8 mm*	R1/8	PQ-FC08MR	1.170"	17 mm
	R1/4	PQ-FC08M2	1.170"	17 mm
	R3/8	PQ-FC08M3	1.250"	19 mm
3/8"	1/4" NPT	PQ-FC12Q		
	3/8" NPT	PQ-FC12W	1.380"	7/8"

Male Connector

(10/pack)

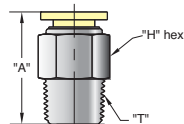

Tubing	Thread "T"	Part No.	"A"	"H" Hex.
1/8"	#10-32	PQ-MC04N	0.899"	
	1/8" NPT	PQ-MC04P	0.836"	7/16"
	1/4" NPT	PQ-MC04Q	0.920"	
5/32"	#10-32	PQ-MC05N	0.899"	7/16"
	1/8" NPT	PQ-MC05P	0.836"	7/16"
	1/4" NPT	PQ-MC05Q	0.920"	9/16"
4 mm*	M5 x 0.8	PQ-MC04M5	0.899"	10 mm
	R1/8	PQ-MC04MR	0.836"	
6 mm*	M5 x 0.8	PQ-MC06M5	0.948"	12 mm
	R1/8	PQ-MC06MR	0.878"	12 mm
	R1/4	PQ-MC06M2	0.873"	14 mm
1/4"	#10-32	PQ-MC08N	0.913"	1/2"
	1/8" NPT	PQ-MC08P	0.913"	1/2"
	1/4" NPT	PQ-MC08Q	0.965"	9/16"
	3/8" NPT	PQ-MC08W	0.965"	11/16"
	1/8" NPT	PQ-MC10P	1.090"	9/16"
5/16"	1/4" NPT	PQ-MC10Q	1.050"	9/16"
	3/8" NPT	PQ-MC10W	1.060"	11/16"
8 mm*	M5 x 0.8	PQ-MC08M5	1.030"	14 mm
	R1/8	PQ-MC08MR	1.030"	14 mm
	R1/4	PQ-MC08M2	1.060"	14 mm
	R3/8	PQ-MC08M3	0.950"	17 mm
3/8"	1/8" NPT	PQ-MC12P	1.280"	11/16"
	1/4" NPT	PQ-MC12Q	1.342"	11/16"
	3/8" NPT	PQ-MC12W	1.241"	11/16"
	1/2" NPT	PQ-MC12Z	1.240"	7/8"
	1/4" NPT	PQ-MC16Q	1.342"	11/16"
1/2"	3/8" NPT	PQ-MC16W	1.241"	7/8"
	1/2" NPT	PQ-MC16Z	1.240"	7/8"

Male Compact Connector

(10/pack)

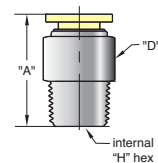

Tubing	Thread "T"	Part No.	"A"	"D" Dia.	"H" Hex.
1/8"	#10-32	PQ-CC04N	0.880"	0.410"	5/64"
	1/8" NPT	PQ-CC04P	0.860"		3/32"
5/32"	#10-32	PQ-CC05N	0.890"	0.400"	5/64"
	1/8" NPT	PQ-CC05P	0.840"	0.410"	3/32"
1/4"	#10-32	PQ-CC08N	0.910"	0.470"	5/64"
	1/8" NPT	PQ-CC08P	0.910"	0.470"	5/32"
	1/4" NPT	PQ-CC08Q	0.970"	0.530"	5/32"
3/8"	1/4" NPT	PQ-CC12Q	1.340"		7/32"
	3/8" NPT	PQ-CC12W	1.240"	0.670"	5/16"

* Fittings have a green release button.

Note: Fittings with pipe thread NPT, R1/8, R1/4 and R3/8 are supplied with pre-applied sealant.



PUSH-QUICK FITTINGS

Run Tee

(5/pack)

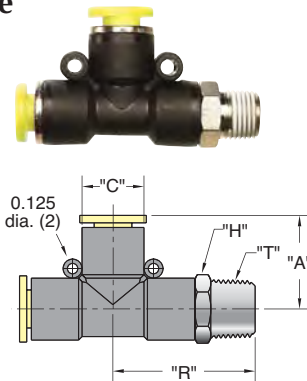

Tube	Thread "T"	Part No.	"A"	"C"	"H" Hex.	"R"
1/8"	1/8" NPT	PQ-RT04P	0.722"	0.410"	7/16"	0.980"
5/32"	#10-32 1/8" NPT	PQ-RT05N PQ-RT05P	0.722"	0.410"	7/16"	0.900" 0.980"
4 mm*	M5 x 0.8 R1/8	PQ-RT04M5 PQ-RT04MR	0.722"	0.410"	10 mm	0.900" 0.980"
6 mm*	M5 x 0.8 R1/8 R1/4	PQ-RT06M5 PQ-RT06MR PQ-RT06M2	0.830"	0.524"	12 mm 12 mm 14 mm	1.030" 1.100" 1.140"
1/4"	#10-32 1/8" NPT 1/4" NPT	PQ-RT08N PQ-RT08P PQ-RT08Q	0.840"	0.524"	1/2" 1/2" 9/16"	1.030" 1.100" 1.230"
5/16"	1/8" NPT 1/4" NPT 3/8" NPT	PQ-RT10P PQ-RT10Q PQ-RT10W	0.880"	0.580"	9/16" 9/16" 11/16"	1.100" 1.230" 1.290"
8 mm*	R1/8 R1/4 R3/8	PQ-RT08MR PQ-RT08M2 PQ-RT08M3	0.880"	0.580"	14 mm	1.290"
3/8"	1/8" NPT 1/4" NPT 3/8" NPT	PQ-RT12P PQ-RT12Q PQ-RT12W	1.100"	0.720"	11/16"	1.380" 1.470" 1.500"

Branch Tee

(5/pack)

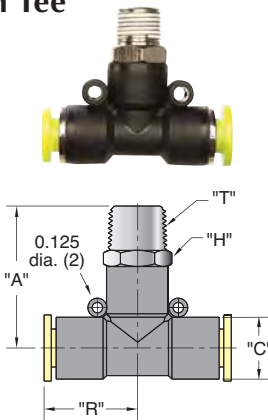

Tube	Thread "T"	Part No.	"A"	"C"	"H" Hex.	"R"
5/32"	#10-32 1/8" NPT	PQ-BT05N PQ-BT05P	0.900" 0.980"	0.410"	7/16"	0.722"
4 mm*	M5 x 0.8 R1/8	PQ-BT04M5 PQ-BT04MR	0.900" 0.980"	0.410"	10 mm	0.722"
6 mm*	M5 x 0.8 R1/8 R1/4	PQ-BT06M5 PQ-BT06MR PQ-BT06M2	1.030" 1.100" 1.140"	0.524"	12 mm 12 mm 14 mm	0.830"
1/4"	#10-32 1/8" NPT 1/4" NPT	PQ-BT08N PQ-BT08P PQ-BT08Q	1.030" 1.100" 1.230"	0.524"	1/2" 1/2" 9/16"	0.840"
5/16"	1/8" NPT 1/4" NPT	PQ-BT10P PQ-BT10Q	1.100" 1.230"	0.580"	9/16"	0.880"
8 mm*	R1/8 R1/4 R3/8	PQ-BT08MR PQ-BT08M2 PQ-BT08M3	1.290" 1.290" 1.290"	0.580"	14 mm	0.880"
3/8"	1/8" NPT 1/4" NPT 3/8" NPT	PQ-BT12P PQ-BT12Q PQ-BT12W	1.290" 1.470" 1.500"	0.720"	11/16"	1.100"

Male Elbow

(10/pack)

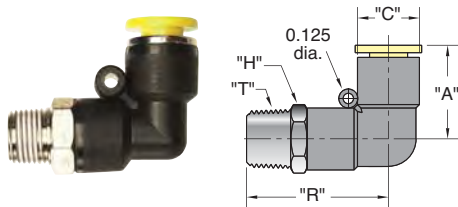

Tube	Thread "T"	Part No.	"A"	"C"	"H" Hex.	"R"
1/8"	#10-32 1/8" NPT	PQ-ME04N PQ-ME04P	0.722"	0.410"	7/16"	0.900" 0.980"
5/32"	#10-32 1/8" NPT 1/4" NPT	PQ-ME05N PQ-ME05P PQ-ME05Q	0.722"	0.410"	7/16"	0.900" 0.980" 1.130"
4 mm*	M5 x 0.8 R1/8	PQ-ME04M5 PQ-ME04MR	0.722"	0.410"	10 mm	0.900" 0.980"
6 mm*	M5 x 0.8 R1/8 R1/4	PQ-ME06M5 PQ-ME06MR PQ-ME06M2	0.830"	0.524"	12 mm 12 mm 14 mm	1.030" 1.100" 1.140"
1/4"	#10-32 1/8" NPT 1/4" NPT 3/8" NPT	PQ-ME08N PQ-ME08P PQ-ME08Q PQ-ME08W	0.840"	0.524"	1/2" 1/2" 9/16" 11/16"	1.030" 1.100" 1.230" 1.290"
5/16"	1/8" NPT 1/4" NPT 3/8" NPT	PQ-ME10P PQ-ME10Q PQ-ME10W	0.880"	0.580"	9/16" 9/16" 11/16"	1.100" 1.230" 1.290"
8 mm*	R1/8 R1/4 R3/8	PQ-ME08MR PQ-ME08M2 PQ-ME08M3	0.880"	0.580"	14 mm	1.290"
3/8"	1/8" NPT 1/4" NPT 3/8" NPT 1/2" NPT	PQ-ME12P PQ-ME12Q PQ-ME12W PQ-ME12Z	1.100"	0.720"	11/16" 11/16" 11/16" 7/8"	1.350" 1.470" 1.500" 1.600"
1/2"	1/4" NPT 3/8" NPT 1/2" NPT	PQ-ME16Q PQ-ME16W PQ-ME16Z	1.160"	0.850"	7/8"	1.550" 1.580" 1.670"

* Fittings have a green release button.
Note: Fittings with pipe thread NPT, R1/8, R1/4 and R3/8 are supplied with pre-applied sealant.

Female Elbow

(5/pack)

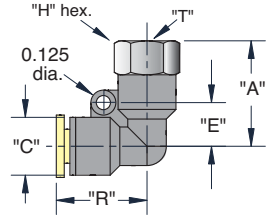

Tubing	Thread "T"	Part No.	"A"	"C"	"H" Hex.	"R"
1/8"	#10-32	PQ-FE04N	0.830"	0.410"	7/16"	0.720"
	1/8" NPT	PQ-FE04P	0.950"			
5/32"	#10-32	PQ-FE05N	0.850"	0.410"	7/16"	0.722"
	1/8" NPT	PQ-FE05P	0.990"			
	1/4" NPT	PQ-FE05Q	0.980"			
1/4"	#10-32	PQ-FE08N	0.940"	0.524"	7/16"	0.840"
	1/8" NPT	PQ-FE08P	1.030"			
	1/4" NPT	PQ-FE08Q	1.190"	0.580"	9/16"	0.900"
	1/8" NPT	PQ-FE10P	1.120"			
5/16"	1/4" NPT	PQ-FE10Q	1.220"	0.720"	11/16"	1.100"
3/8"	1/4" NPT	PQ-FE12Q	1.390"			
	3/8" NPT	PQ-FE12W	1.420"		7/8"	

Extended Elbow

(5/pack)

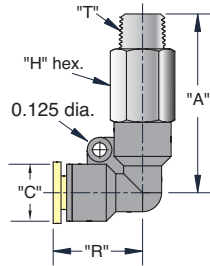

Tubing	Thread "T"	Part No.	"A"	"C"	"H" Hex.	"R"
5/32"	#10-32	PQ-EE05N	0.722"	0.410"	7/16"	1.360"
	1/8" NPT	PQ-EE05P	1.480"			
1/4"	1/8" NPT	PQ-EE08P	0.840"	0.524"	1/2"	1.640"
	1/4" NPT	PQ-EE08Q			9/16"	1.820"
	1/2" NPT	PQ-EE08W			11/16"	1.940"
5/16"	1/8" NPT	PQ-EE10P	0.900"	0.580"	1/2"	1.810"
	1/4" NPT	PQ-EE10Q			9/16"	1.900"
3/8"	3/8" NPT	PQ-EE10W	1.100"	0.720"	11/16"	2.010"
	1/4" NPT	PQ-EE12Q			9/16"	2.170"
	3/8" NPT	PQ-EE12W			11/16"	2.170"
1/2"	1/2" NPT	PQ-EE12Z	1.160"	0.850"	7/8"	2.560"
	3/8" NPT	PQ-EE16W			11/16"	2.470"
	1/2" NPT	PQ-EE16Z			7/8"	2.600"

Universal Elbow

(5/pack)

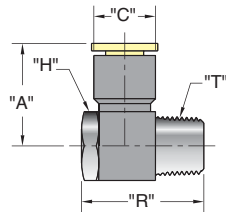

Tubing	Thread "T"	Part No.	"A"	"C"	"R"	"H" Hex.
5/32"	#10-32	PQ-UE05N	0.820"	0.410"	0.790"	5/16"
	1/8" NPT	PQ-UE05P	0.920"		1.020"	7/16"
4 mm*	M5 x 0.8	PQ-UE04M5	0.831"	0.410"	0.790"	8 mm
	R1/8	PQ-UE04MR	0.921"		0.970"	10 mm
6 mm*	M5 x 0.8	PQ-UE06M5	0.976"	0.524"	0.790"	12 mm
	R1/8	PQ-UE06MR			0.970"	12 mm
	R1/4	PQ-UE06M2			1.059"	1.140"
1/4"	#10-32	PQ-UE08N	0.940"	0.524"	0.790"	1/2"
	1/8" NPT	PQ-UE08P			1.020"	1/2"
	1/4" NPT	PQ-UE08Q			1.120"	1.150"
5/16"	1/8" NPT	PQ-UE10P	1.120"	0.580"	1.020"	9/16"
	1/4" NPT	PQ-UE10Q			1.150"	9/16"
	3/8" NPT	PQ-UE10W			1.430"	11/16"
8 mm*	R1/8	PQ-UE08MR	1.120"	0.580"	1.000"	14 mm
	R1/4	PQ-UE08M2			1.140"	
	R3/8	PQ-UE08M3			1.410"	
3/8"	1/4" NPT	PQ-UE12Q	1.320"	0.720"	1.180"	11/16"
	3/8" NPT	PQ-UE12W			1.430"	

Y Connector

(5/pack)

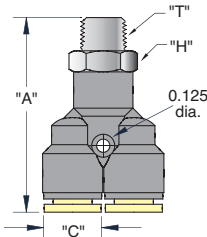

Tubing	Thread "T"	Part No.	"A"	"C"	"H" Hex.
1/8"	#10-32	PQ-YC04N	1.630"	0.410"	7/16"
	1/8" NPT	PQ-YC04P	1.660"		
5/32"	#10-32	PQ-YC05N	1.630"	0.410"	7/16"
	1/8" NPT	PQ-YC05P	1.660"		
1/4"	#10-32	PQ-YC08N	1.690"	0.524"	1/2"
	1/8" NPT	PQ-YC08P	1.770"		
	1/4" NPT	PQ-YC08Q	1.830"		
5/16"	1/8" NPT	PQ-YC10P	1.830"	0.580"	9/16"
	1/4" NPT	PQ-YC10Q	1.900"		
3/8"	1/4" NPT	PQ-YC12Q	2.340"	0.720"	11/16"
	3/8" NPT	PQ-YC12W	2.400"		
1/2"	3/8" NPT	PQ-YC16W	2.500"	0.850"	7/8"
	1/2" NPT	PQ-YC16Z	2.600"		

* Fittings have a green release button.

Note: Fittings with pipe thread NPT, R1/8, R1/4 and R3/8 are supplied with pre-applied sealant.



PUSH-QUICK FITTINGS

Male Angle Connector

(10/pack)

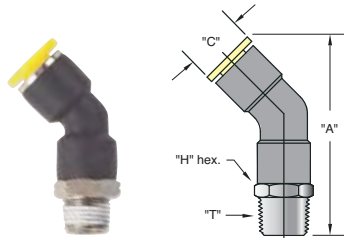

Tubing	Thread "T"	Part No.	"H" Hex.	"A"	"C"
1/8"	#10-32 1/8" NPT	PQ-MA04N PQ-MA04P	7/16"	1.454" 1.474"	0.410"
5/32"	#10-32 1/8" NPT	PQ-MA05N PQ-MA05P	7/16"	1.454" 1.474"	0.410"
4 mm*	M5 x 0.8 R1/8	PQ-MA04M5 PQ-MA04MR	10 mm	1.454" 1.474"	0.410"
6 mm*	M5 x 0.8 R1/8 R1/4	PQ-MA06M5 PQ-MA06MR PQ-MA06M2	12 mm 10 mm 14 mm	1.556" 1.556" 1.616"	0.520"
1/4"	#10-32 1/8" NPT 1/4" NPT 3/8" NPT	PQ-MA08N PQ-MA08P PQ-MA08Q PQ-MA08W	1/2" 1/2" 9/16" 11/16"	1.620" 1.620" 1.682" 1.722"	0.520"
5/16"	1/8" NPT 1/4" NPT	PQ-MA10P PQ-MA10Q	9/16"	1.800"	0.580"
3/8"	1/8" NPT 1/4" NPT 3/8" NPT	PQ-MA12P PQ-MA12Q PQ-MA12W	11/16"	1.823" 1.923" 1.943"	0.720"
1/2"	1/4" NPT 3/8" NPT 1/2" NPT	PQ-MA16Q PQ-MA16W PQ-MA16Z	7/8"	1.965" 2.125" 2.195"	0.830"

Stack Elbow

(5/pack)

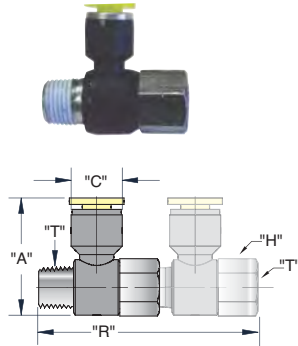

Two fittings shown stacked

Tubing	Thread "T"	Part No.	"A"	"C"	"R"	"H" Hex.
5/32"	#10-32 1/8" NPT	PQ-SE05N PQ-SE05P	0.980" 1.095"	0.410"	1.435"	5/16" 5/16"
1/4"	#10-32 1/8" NPT 1/4" NPT	PQ-SE08N PQ-SE08P PQ-SE08Q	1.165" 1.200" 1.365"	0.524"	2.250" 2.250" 2.600"	1/2" 1/2" 11/16"
5/16"	1/4" NPT 3/8" NPT	PQ-SE10Q PQ-SE10W	1.425" 1.570"	0.580"	2.600" 2.900"	11/16" 3/4"
3/8"	1/4" NPT 3/8" NPT	PQ-SE12Q PQ-SE12W	1.625" 1.690"	0.720"	2.530" 2.970"	11/16" 3/4"
1/2"	3/8" NPT 1/2" NPT	PQ-SE16W PQ-SE16Z	1.740" 1.950"	0.850"	2.970" 3.160"	3/4" 1"

Manifold Mount

(5/pack)

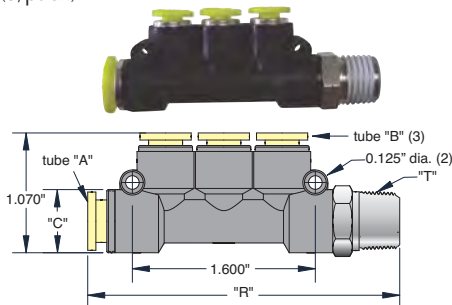

Tube "A"	Tube "B"	Thread "T"	Part No.	"C"	"R"
1/4"	5/32"	1/8" NPT	PQ-MM0805P	0.524"	2.665"
5/16"	1/4"	1/4" NPT	PQ-MM1008Q	0.580"	2.820"



* Fittings have a green release button.

Note: Fittings with pipe thread NPT, R1/8, R1/4 and R3/8 are supplied with pre-applied sealant.

Bulkhead Connector

(5/pack)

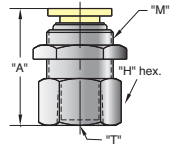

Tube	Thread "T"	Part No.	"A"	Thread "M"	"H" Hex.
1/8"	1/8" NPT	PQ-BC04P	1.052"	M12x1	9/16"
5/32"	1/8" NPT	PQ-BC05P	1.052"	M12x1	9/16"
4 mm*	R1/8	PQ-BC04MR	1.052"	M12x1	14 mm
6 mm*	R1/8	PQ-BC06MR	1.080"	M14x1	17 mm
	R1/4	PQ-BC06M2	1.150"		
1/4"	1/8" NPT	PQ-BC08P	1.084"	M14x1	11/16"
	1/4" NPT	PQ-BC08Q	1.209"		
5/16"	1/8" NPT	PQ-BC10P	1.150"	M16x1	11/16"
	1/4" NPT	PQ-BC10Q	1.195"		
8 mm*	R1/8	PQ-BC08MR	1.125"	M16x1	17 mm
	R1/4	PQ-BC08M2	1.170"		
3/8"	1/4" NPT	PQ-BC12Q	1.400"	M20x1	7/8"
	3/8" NPT	PQ-BC12W	1.415"		
1/2"	1/2" NPT	PQ-BC16Z	1.525"	M22x1	1"

Bulkhead Union

(5/pack)

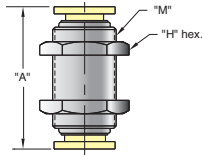

Tube	Part No.	"A"	Thread "M"	"H" Hex.
1/8"	PQ-BU04	0.415"	M12 x 1	14 mm
5/32"	PQ-BU05	1.370"	M12 x 1	5/8"
6 mm*	PQ-BU06M	1.390"	M14 x 1	17 mm
1/4"	PQ-BU08	1.421"	M14 x 1	3/4"
5/16"	PQ-BU10	1.610"	M16 x 1	3/4"
3/8"	PQ-BU12	1.723"	M20 x 1	15/16"
1/2"	PQ-BU16	1.770"	M22 x 1	1"

Straight Union

(10/pack)

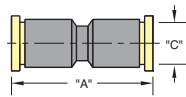

Tube	Part No.	"A"	"C"
1/8"	PQ-SU04	1.240"	0.410"
5/32"	PQ-SU05	1.239"	0.410"
6 mm*	PQ-SU06M	1.500"	0.524"
1/4"	PQ-SU08	1.500"	0.524"
5/16"	PQ-SU10	1.540"	0.580"
3/8"	PQ-SU12	1.851"	0.720"
1/2"	PQ-SU16	1.810"	0.850"

Elbow Union

(10/pack)

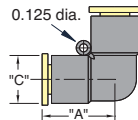

Tube	Part No.	"A"	"C"
1/8"	PQ-EU04	0.710"	0.410"
5/32"	PQ-EU05	0.722"	0.410"
6 mm*	PQ-EU06M	0.830"	0.524"
1/4"	PQ-EU08	0.840"	0.524"
5/16"	PQ-EU10	0.880"	0.580"
3/8"	PQ-EU12	1.100"	0.720"
1/2"	PQ-EU16	1.130"	0.850"

Tee Union

(10/pack)

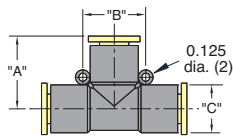

Tube	Part No.	"A"	"B"	"C"
1/8"	PQ-TU04	0.710"	0.656"	0.410"
5/32"	PQ-TU05	0.722"	0.656"	0.410"
6 mm*	PQ-TU06M	0.830"	0.740"	0.524"
1/4"	PQ-TU08	0.840"	0.740"	0.524"
5/16"	PQ-TU10	0.880"	0.800"	0.580"
3/8"	PQ-TU12	1.100"	0.944"	0.720"
1/2"	PQ-TU16	1.130"	1.120"	0.850"

Cross Union

(5/pack)

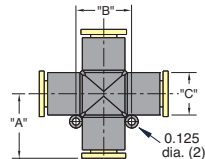

Tube	Part No.	"A"	"B"	"C"
1/8"	PQ-CU04	0.710"	0.560"	0.410"
5/32"	PQ-CU05	0.722"	0.656"	0.410"
6 mm*	PQ-CU06M	0.830"	0.740"	0.524"
1/4"	PQ-CU08	0.840"	0.740"	0.524"
5/16"	PQ-CU10	0.880"	0.800"	0.580"
3/8"	PQ-CU12	1.100"	0.944"	0.720"

Manifold Union

(5/pack)

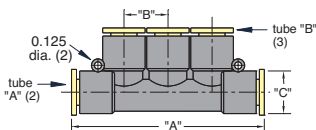

Tube "A"	Tube "B"	Part No.	"A"	"B"	"C"
5/32"	1/8"	PQ-MU0504	2.312"	0.500"	0.560"
6 mm*	5/32"	PQ-MU06M05	2.435"	0.531"	0.524"
1/4"	5/32"	PQ-MU0805	2.435"	0.531"	0.524"
5/16"	1/4"	PQ-MU1008	2.435"	0.580"	0.580"
3/8"	1/4"	PQ-MU1208	2.312"	0.562"	0.725"

* Fittings have a green release button

Note:
Fittings with pipe thread NPT, R1/8, R1/4 and R3/8 are supplied with pre-applied sealant.



PUSH-QUICK FITTINGS

Reduced Union

(10/pack)

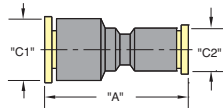

Tubing	Part No.	"A"	"C1"	"C2"
5/32"-1/8"	PQ-RU0504	1.230"	0.410"	0.410"
6 mm*-5/32"	PQ-RU06M05	1.367"	0.524"	0.410"
1/4"-1/8"	PQ-RU0804	1.367"	0.524"	0.410"
5/16"-1/4"	PQ-RU1008	1.550"	0.580"	0.524"
3/8"-1/4"	PQ-RU1208	1.666"	0.720"	0.524"
1/2"-3/8"	PQ-RU1612	1.810"	0.850"	0.720"

Y Union

(5/pack)

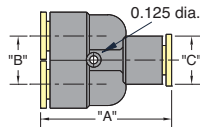

Tubing	Part No.	"A"	"B"	"C"
1/8"	PQ-YU04	1.340"	0.415"	0.410"
5/32"	PQ-YU05	1.318"	0.517"	0.410"
6 mm*	PQ-YU06M	1.495"	0.531"	0.524"
1/4"	PQ-YU08	1.495"	0.531"	0.524"
5/16"	PQ-YU10	1.495"	0.590"	0.580"
3/8"	PQ-YU12	2.017"	0.720"	0.720"
1/2"	PQ-YU16	2.070"	0.840"	0.840"

Reduced Branch

(5/pack)

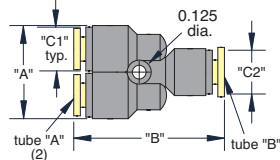

Tube "A"	Tube "B"	Part No.	"A"	"B"	"C1"	"C2"
1/8"	5/32"	PQ-RB0504	0.830"	1.340"	0.420"	0.410"
5/32"	1/4"	PQ-RB0805	0.830"	1.390"	0.410"	0.524"
1/4"	5/16"	PQ-RB1008	1.025"	1.670"	0.524"	0.580"
1/4"	3/8"	PQ-RB1208	1.025"	1.780"	0.524"	0.720"
3/8"	1/2"	PQ-RB1612	1.420"	2.050"	0.720"	0.850"

Tee Reducer

(5/pack)

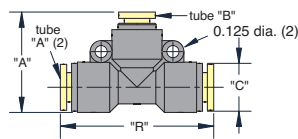

Tube "A"	Tube "B"	Part No.	"A"	"C"	"R"
5/32"	1/8"	PQ-TR0504	0.910"	0.410"	1.385"
1/4"	5/32"	PQ-TR0805	1.050"	0.524"	1.570"
5/16"	1/4"	PQ-TR1008	1.170"	0.580"	1.835"
3/8"	1/4"	PQ-TR1208	1.380"	0.720"	2.160"
1/2"	3/8"	PQ-TR1612	1.600"	0.850"	2.240"

Elbow Reducer

(5/pack)

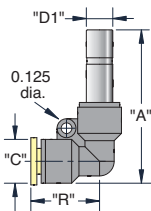

Tubing	Part No.	"A"	"C"	"D1"	"R"
1/8"	PQ-ER0405	1.480"	0.420"	5/32"	0.710"
5/32"	PQ-ER0508	1.640"	0.410"	1/4"	0.722"
1/4"	PQ-ER0810	1.765"	0.524"	5/16"	0.840"
5/16"	PQ-ER1012	2.020"	0.580"	3/8"	0.880"
3/8"	PQ-ER1216	2.260"	0.720"	1/2"	1.100"

Plug-In Elbow

(5/pack)

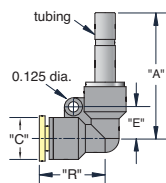

Tubing	Part No.	"A"	"C"	"E"	"R"
1/8"	PQ-PE04	1.290"	0.410"	0.328"	0.722"
5/32"	PQ-PE05	1.290"	0.410"	0.328"	0.722"
1/4"	PQ-PE08	1.550"	0.524"	0.370"	0.840"
5/16"	PQ-PE10	1.600"	0.580"	0.430"	0.900"
3/8"	PQ-PE12	1.850"	0.720"	0.472"	1.100"
1/2"	PQ-PE16	1.940"	0.850"	0.570"	1.160"

Tube Reducer (Stem)

(10/pack)

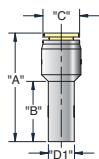

Tubing	Part No.	"A"	"B"	"C"	"D1"
1/8"	PQ-TRS0405	1.320"	0.690"	0.410"	5/32"
5/32"	PQ-TRS0508	1.400"	0.810"	0.524"	1/4"
1/4"	PQ-TRS0810	1.480"	0.850"	0.580"	5/16"
1/4"	PQ-TRS0812	1.610"	0.990"	0.720"	3/8"
3/8"	PQ-TRS1216	1.730"	0.990"	0.850"	1/2"

* Fittings have a green release button.

Note: Fittings with pipe thread NPT, R1/8, R1/4 and R3/8 are supplied with pre-applied sealant.

Stem Reducer

(10/pack)

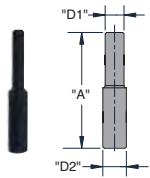

Tubing	Part No.	"A"	"D1"	"D2"
5/32"	PQ-SR0508	1.417"	5/32"	1/4"
1/4"	PQ-SR0810	1.535"	1/4"	5/16"
5/16"	PQ-SR1012	1.811"	5/16"	3/8"
3/8"	PQ-SR1216	2.126"	3/8"	1/2"

Stem Coupler

(10/pack)

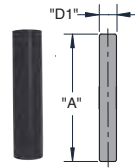

Tubing	Part No.	"A"	"D1"
5/32"	PQ-SC05	1.378"	5/32"
1/4"	PQ-SC08	1.457"	1/4"

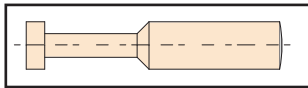

Push-Quick Plugs

Clippard offers a variety of Push-Quick Plugs in sizes to fit 1/8" through 3/8" O.D. tubing.

These plastic plugs may be used to plug the port of a Push-Quick Fitting for later use. Used as a temporary plug,

they may later be removed and tubing inserted to connect to an additional line of a circuit.

Part No.	Description	Part No.	Description
PQ-PG04	1/8" O.D. Tube	PQ-PG08	1/4" O.D. Tube
PQ-PG05	5/32" O.D. Tube	PQ-PG10	5/16" O.D. Tube
PQ-PG06M	6 mm O.D. Tube	PQ-PG12	3/8" O.D. Tube

Push-Quick Fitting Adapters

Clippard offers a variety of accessories that are designed for use with Push-Quick Fittings. These include special #10-32 threaded adapters in both male (p/n 11674) and female (p/n 11675) thread configurations and adapters that can be used to plug a Push-Quick fitting.

The threaded adapters insert into Push-Quick Fittings and provide either a male or female thread that can be used to mount any Clippard product with a #10-32 threaded inlet. This allows the direct attachment of the product to a Push-Quick Fitting without hoses or additional fittings.

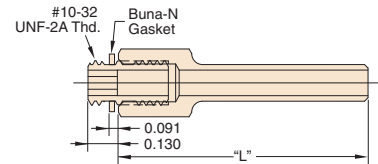

Part No.	"L"	Tube Size
11674-05	1.063"	5/32" OD
11674-08	1.031"	1/4" OD
11674-12	1.218"	3/8" OD

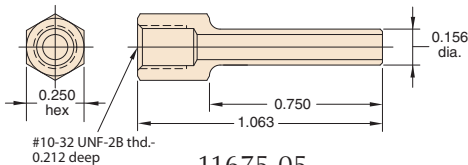

11675-05
5/32" O.D. Tube

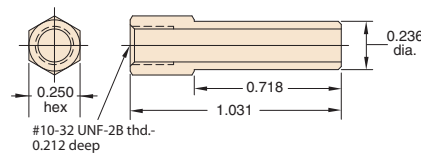

11675-08
1/4" O.D. Tube

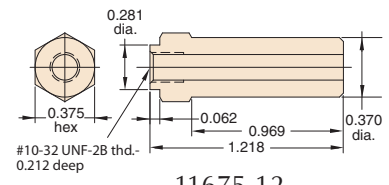

11675-12
3/8" O.D. Tube

Figure 1 shows an MAV-3 3-Way Valve connected to a PQ-RT05P Run Tee using a 11674-05 Adapter. In this example, the Run Tee is connected to a 1/8" NPT supply pipe.

Figure 2 shows an IND-1M-WH Pressure Indicator connected to a PQ-TU08 Tee Union using a 11675-08 Adapter. If one of the branches of a Push-Quick Fitting is to be used as a temporary pressure gauge port, the PQ-PGXX series of Plugs can be used when the gauge is not in place. Plugs may also be used if Push-Quick Fitting branches are intended for future additions to the circuit, but have no current need.

Figure 3 shows a PQ-CU Cross Union with one branch plugged with a PQ-PG08 Plug.

MAV-3



Figure 1

11674

Run Tee



IND-1M-WH



Figure 2

11675

Tee Union



PQ-PGXX



Figure 3

Cross Union

