



NEW! NEEDLE VALVES

Needle Valves are used to control the rate of flow in a pneumatic system by controlling flow in both directions. Material enters the input port, travels through an adjustable orifice and out the output port. Available with multiple port sizes, flow rates, mounting options and adjustment styles.

Medium: Air, Water or Oil

Input Pressure: 300 psig max.

Air Flow: GNV-3: 11 scfm @ 100 psig
 GNV-4: 45 scfm @ 100 psig
 GNV-5: 60 scfm @ 100 psig

Materials: Electroless nickel plated brass body and needle, anodized aluminum housing

Mounting: Direct, in-line or cartridge style

Ports: Rotating input allows 360° positioning

Adjustment: Recessed slotted needle or knurled knob

Seals: Nitrile standard. FKM optional.

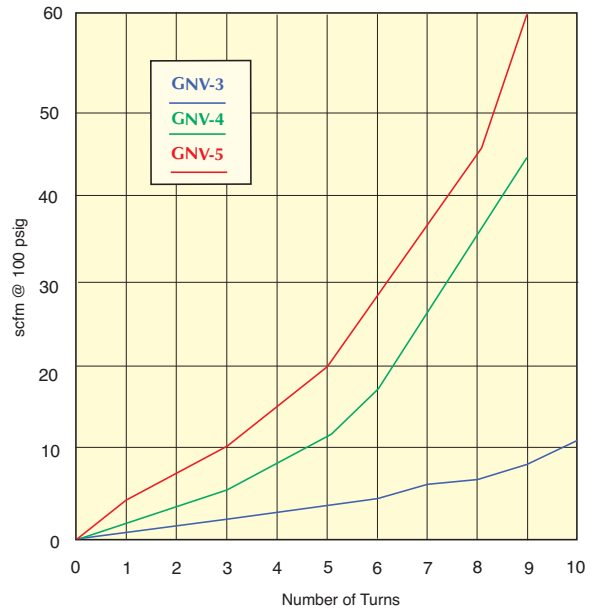
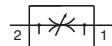

- Provide bidirectional flow control
- Rugged and compact design
- Multiple mounting options
- 360° rotating ports
- Ideal for use with Push-Quick fittings

Direct Mount Needle Valves, 1/8" NPT



(GNV-3R shown)

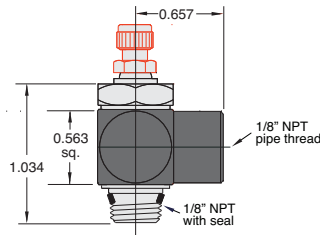

Part No.	Description
GNV-3R	Needle Valve, 1/8" NPT, Screwdriver Slot
GNV-3K	Needle Valve, 1/8" NPT, Knurled Knob

Direct Mount Needle Valves, 1/4" NPT



(GNV-4K shown)

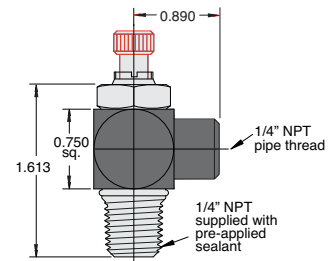

Part No.	Description
GNV-4R	Needle Valve, 1/4" NPT, Screwdriver Slot
GNV-4K	Needle Valve, 1/4" NPT, Knurled Knob

Direct Mount Needle Valves, 3/8" NPT



(GNV-5K shown)

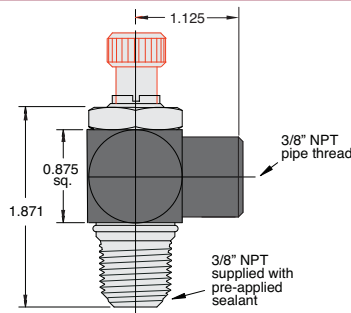

Part No.	Description
GNV-5R	Needle Valve, 3/8" NPT, Screwdriver Slot
GNV-5K	Needle Valve, 3/8" NPT, Knurled Knob

In-Line Mount Needle Valves, 1/8" NPT



(GNV-3RI shown)

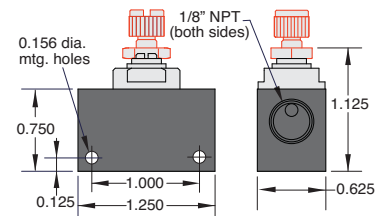

Part No.	Description
GNV-3RI	Needle Valve, 1/8" NPT, Screwdriver Slot
GNV-3KI	Needle Valve, 1/8" NPT, Knurled Knob

In-Line Mount Needle Valves, 1/4" NPT

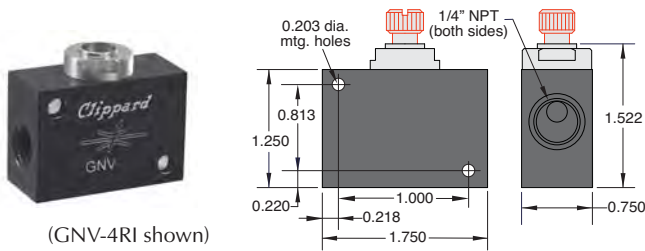

(GNV-4RI shown)

Part No.	Description
GNV-4RI	Needle Valve, 1/4" NPT, Screwdriver Slot
GNV-4KI	Needle Valve, 1/4" NPT, Knurled Knob

In-Line Mount Needle Valves, 3/8" NPT

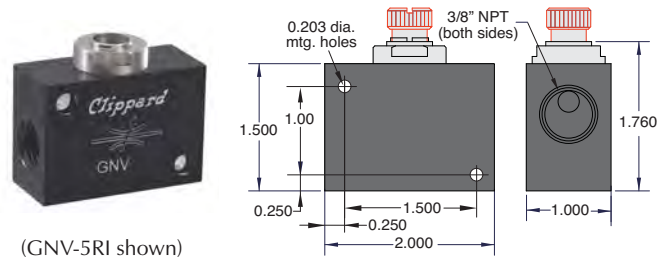

(GNV-5RI shown)

Part No.	Description
GNV-5RI	Needle Valve, 3/8" NPT, Screwdriver Slot
GNV-5KI	Needle Valve, 3/8" NPT, Knurled Knob

Cartridge Needle Valves

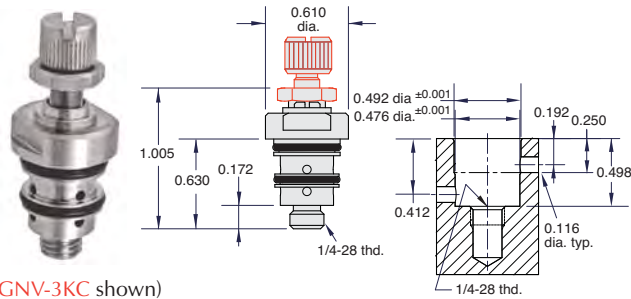

(GNV-3KC shown)

Part No.	Description
GNV-3RC	Cartridge Needle Valve, Screwdriver Slot
GNV-3KC	Cartridge Needle Valve, Knurled Knob

Cartridge Needle Valves

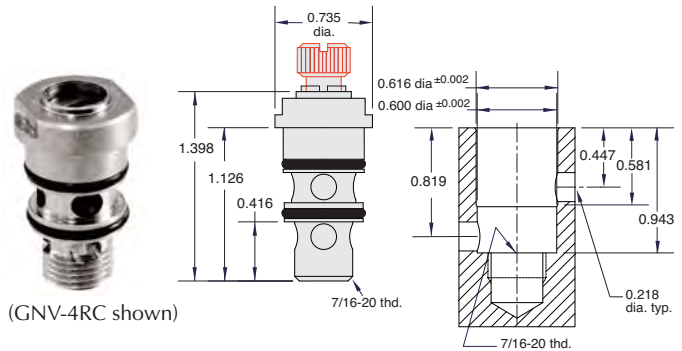

(GNV-4RC shown)

Part No.	Description
GNV-4RC	Cartridge Needle Valve, Screwdriver Slot
GNV-4KC	Cartridge Needle Valve, Knurled Knob

Cartridge Needle Valves

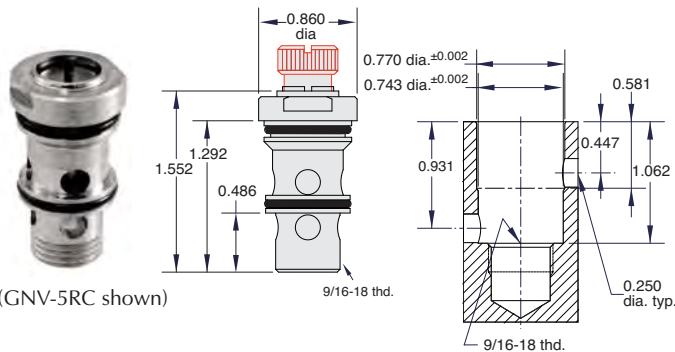

(GNV-5RC shown)

Part No.	Description
GNV-5RC	Cartridge Needle Valve, Screwdriver Slot
GNV-5KC	Cartridge Needle Valve, Knurled Knob



Clippard Push-Quick

Fittings provide a simple method to connect pneumatic components to each other and system piping, and accept both flexible hose and rigid tubing. Both fittings and tubing are available in many styles, sizes and colors.

Metric line available. Visit www.clippard.com