

ET-4 Elevating Table

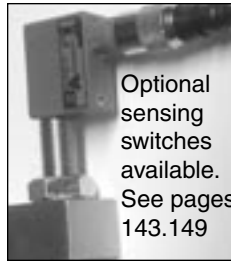

Optional sensing switches available. See pages 143.149

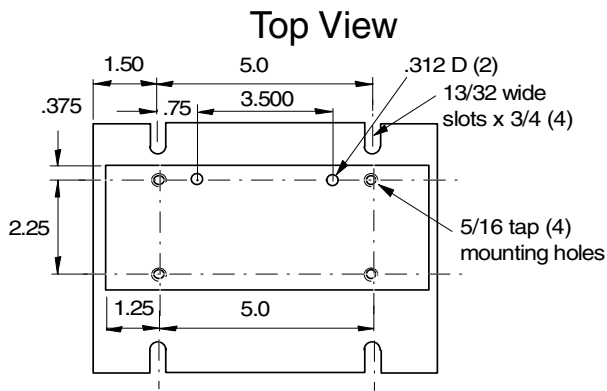
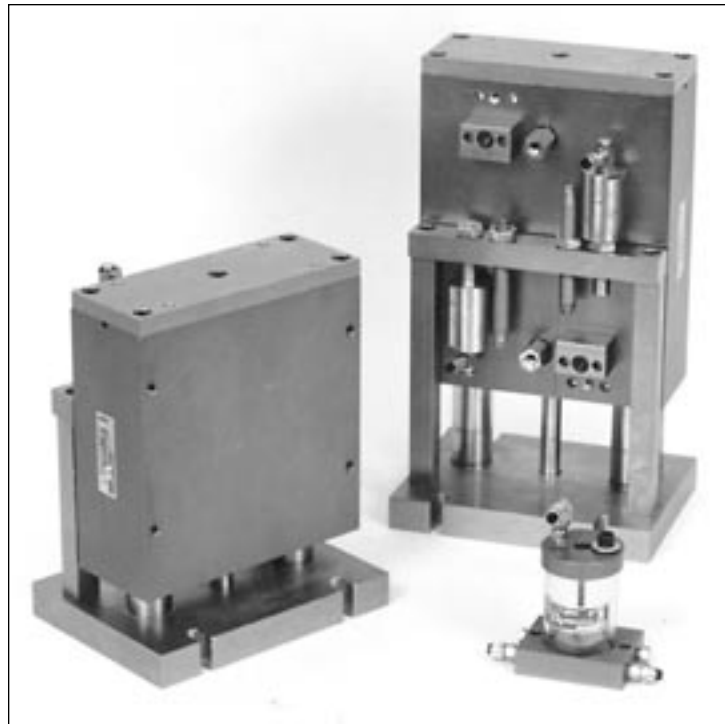

J

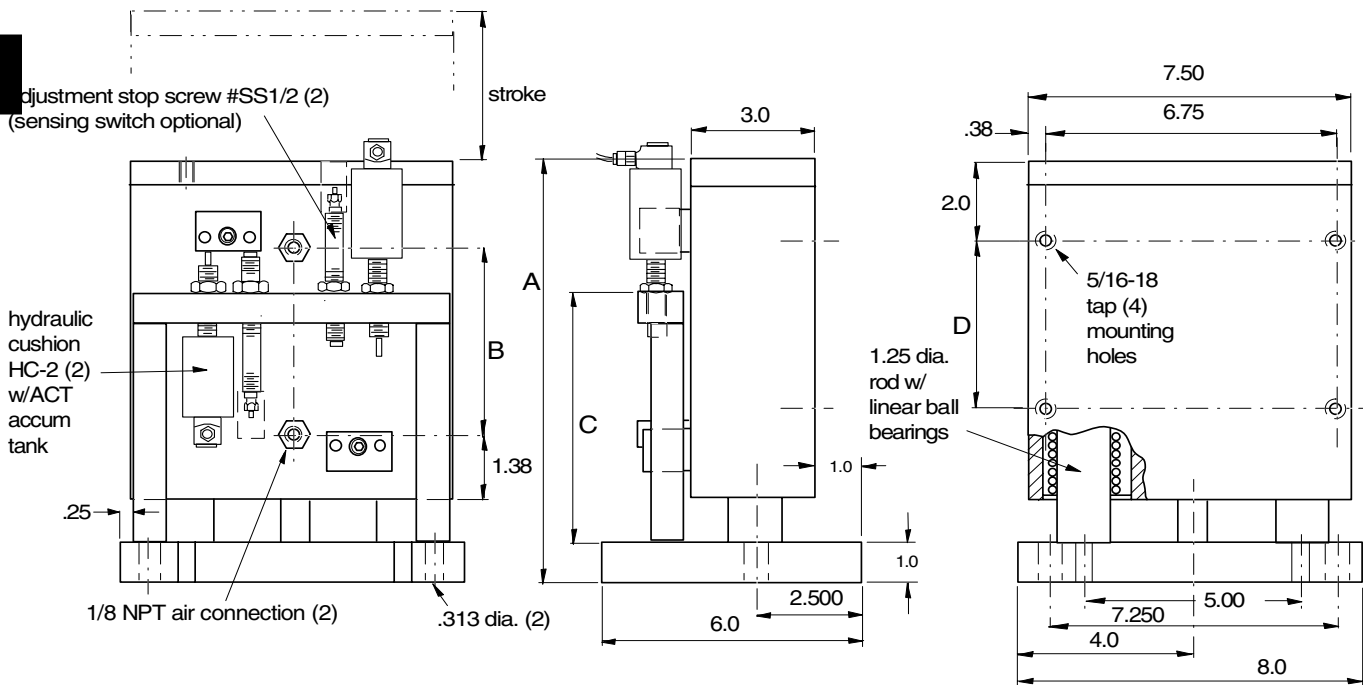

Type	Stroke	A	B	C	D	Force @ 80psi	Weight
ET-4-2	0-2"	10.49	4.50	6.00	4.00	190 lbs	41 lbs
ET-4-4	0-4"	12.49	6.50	8.00	6.00	190 lbs	49 lbs

Technical data

- 2" Bore
- Stroke designed with built in stopscrews with fine threads.
- The stopscrews can be used with sensing switches.
- Designed for production rates and long life.
- Seal kits and rebuild kits available.

Operating medium
Operating pressure
Repeat accuracy
Air connection

Compressed air or hydraulic oil
60-100 psi
±0.0005 in
1/8 NPT