

Part Description:

The single tab end fastener assembly is comprised of a button head socket cap screw and a single tab wing clip. The single tab end fastener provides a fixed, 90 degree, moderate-strength connection that is completely hidden. The single winged tab is used for closed face, radius and angled profiles; the winged tab prevents the mating profile from rotating while the straight end is flush with the mounting profile. This connection method requires two machining services; an end tap on the mounting profile and an access hole in the mating profile in order to reach the screw head. **Additional Information:** Wing clips are available separately (without the button head socket cap screw) for instances where you want to create your own custom assembly.

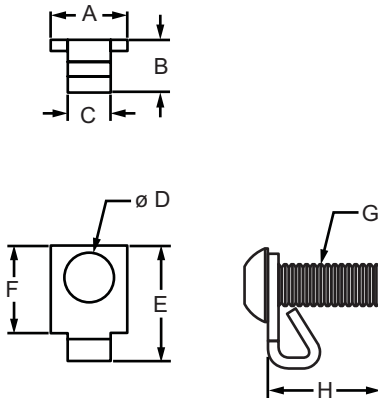

Part No.	Series	Type	Material	Color	A	B	C	D	E	F	G	H	Weight
3383	10	Assembly	Steel	Black	.431"	.293"	.240"	.275"	.645"	.489"	1/4-20	.750"	.015 lb
3183	10	Clip		Black	.431"	.293"	.240"	.275"	.645"	.489"	—	—	.005 lb
3389	15	Assembly		Black	.625"	.450"	.300"	.354"	.916"	.766"	5/16-18	1.000"	.037 lb
3189	15	Clip		Black	.625"	.450"	.300"	.354"	.916"	.766"	—	—	.010 lb
25-3383	25	Assembly		Bright	10.94mm	7.44mm	6.09mm	6.98mm	16.38mm	12.42mm	M6	16.00mm	.0068 kg
25-3183	25	Clip		Bright	10.94mm	7.44mm	6.09mm	6.98mm	16.38mm	12.42mm	—	—	.0027 kg
40-3389	40	Assembly		Bright	15.87mm	11.43mm	7.62mm	8.99mm	23.26mm	19.45mm	M8	25.00mm	.0168 kg
40-3189	40	Clip		Bright	15.87mm	11.43mm	7.62mm	8.99mm	23.26mm	19.45mm	—	—	.0064 kg

Required Machining Services

Machining Type	Profile Machined	Reference Page
Tap Profile End	Mounting Profile	861
Access Hole	Mating Profile	863

Single Tab End Fastener Assembly

